

# 3K SOĞUTMA REFRIGERATION

# MİSYON

Kuruluşumuzdan bugüne; çözümlerimiz, güvenilirliğimiz ve yüksek iş ahlakımız ile müşterilerin ve çalışanların ilk tercihi olmakla beraber yüksek standartlı ve kaliteli hizmet vererek müşteri memnuniyetini en üst düzeye çıkarmak. Bilgi çağının getirdiği yeni kaçınılmaz gerçekler doğrultusunda çözüm ortağı kimliği ile işletmelerin ihtiyaçlarına çözüm odaklı yaklaşarak, çalışma ve çabalarımızı sürdürmeye devam ederken geride kimseyi bırakmamak. **3K Soğutma** ailesi olarak görerek bakmak ve anlayarak çözmek için her zaman çalışanlarımız ve müşterilerimizin yanında olacağız





# VİZYON

İçinde bulunduğu sektöre liderlik eden, çalışanlarına ilham veren, mükemmellik ile katma değer yaratan seçkin bir dolap firması olmanın yanı sıra ürün ve hizmetlerimizi sürekli olarak geliştirerek en yüksek kaliteyi ve eksiksiz müşteri memnuniyetini sunmaya odaklanıyoruz. Asıl amacımız hizmetlerimizin sürekliliğini sağlamak ve yapmış olduğumuz yatırımlar ile Ülke ekonomisine katkı sağlamaktır. Bunun yanı sıra istihdam yaratmak ve Kuruluş amacından sapmadan istikrarlı bir şekilde ilerlemek ilkelerimizdendir.







**DIŞTAN MOTORLU** | REMOTE

<b>ŞARKÜTERİ</b> COUNTERS	1-2
<b>SYDNEY CG</b>	3-4
<b>SYDNEY FG</b>	5-6
<b>SYDNEY AFG</b>	7-8
<b>SYDNEY SS. CG</b>	9-10
<b>SYDNEY SS. FG</b>	11-12
<b>SALTA FG</b>	13-14
<b>SÜTLÜK</b> MULTIDECKS	15-16
<b>MELBOURNE</b>	17-18
<b>MELBOURNE DGD</b>	19-20
<b>MELBOURNE D-SGD</b>	21-22
<b>MELBOURNE OGD</b>	23-24
<b>MELBOURNE HB</b>	25-26
<b>MELBOURNE HB DGD</b>	27-28
<b>MELBOURNE HB D-SGD</b>	29-30
<b>MELBOURNE HB D-OGD</b>	31-32
<b>MELBOURNE WB</b>	33-34
<b>MELBOURNE RB</b>	35-36
<b>MELBOURNE FV</b>	37-38
<b>DARWIN</b>	39-40
<b>MARLO</b>	41-42
<b>SÜTLÜK</b> MULTIDECKS	43-44
<b>MARBELLA</b>	45-46
<b>DERİN DONDURUCU</b> CABINETS AND MIX CABINETS MANAMA	
<b>MANAMA</b>	47-48

**İÇTEN MOTORLU** | PLUG-IN

<b>ŞARKÜTERİ</b> COUNTERS	
<b>SPARTA CG -FG</b>	49-50
<b>SPARTA AFG</b>	51-52
<b>SPARTA SS.CG-FG</b>	53-54
<b>STOW FG</b>	55-56
<b>HAWAII</b>	57-58
<b>ŞARKÜTERİ</b> COUNTERS	59-60
<b>SÜTLÜK</b> MULTIDECKS	
<b>MANDURAH</b>	61-62
<b>MANDURAH DGD</b>	63-64
<b>MANDURAH FV</b>	65-66
<b>DRY AGED</b>	67-68
<b>KISA SÜTLÜK</b> SV - MULTIDECKS	
<b>MACON</b>	69-70
<b>PROMOSYON</b> PROMOTION	
<b>BRISBANE</b>	71-72
<b>BRISBANE NC. O-SGD</b>	73-74
<b>SOĞUK HAVA DEPOLARI</b> COLD ROOMS	75
<b>SOĞUTMA SİSTEMLERİ</b> COOLING SYSTEMS	75

ŞARKÜTERİ | COUNTERS



DIŐTAN MOTORLU | REMOTE

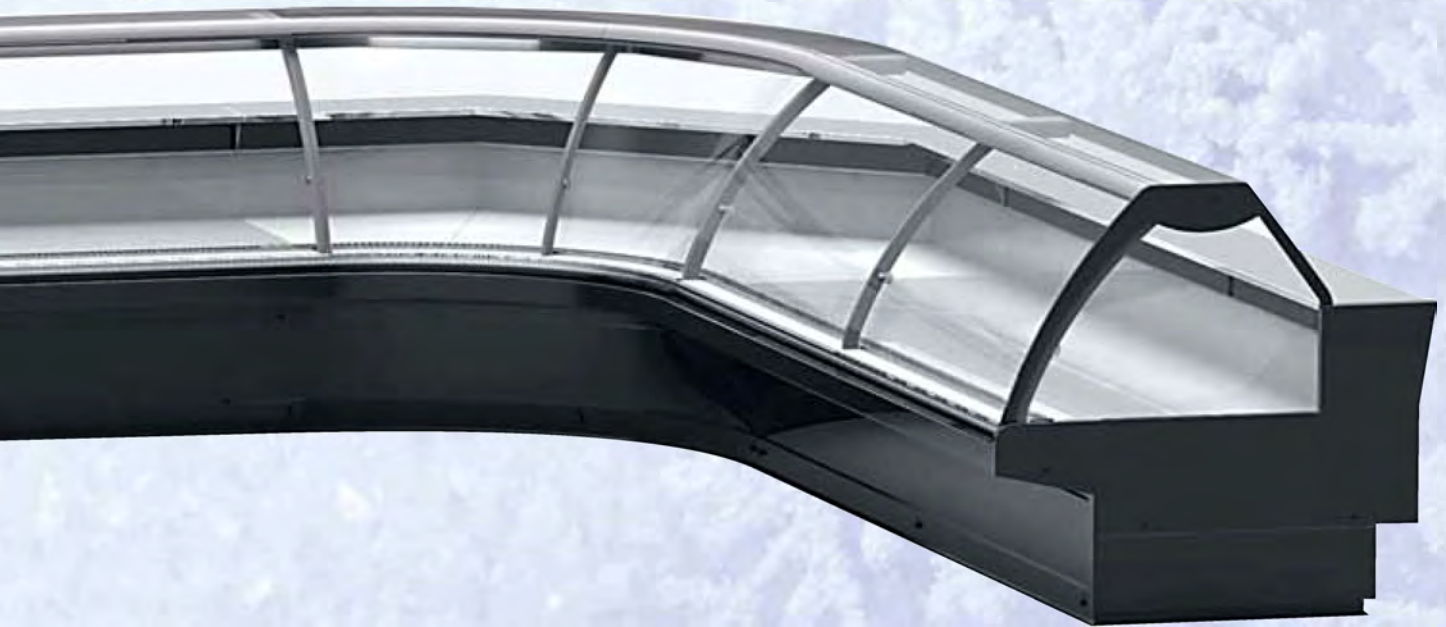



## SYDNEY CG

DIŐTAN MOTORLU | REMOTE

SYDNEY AK.CG

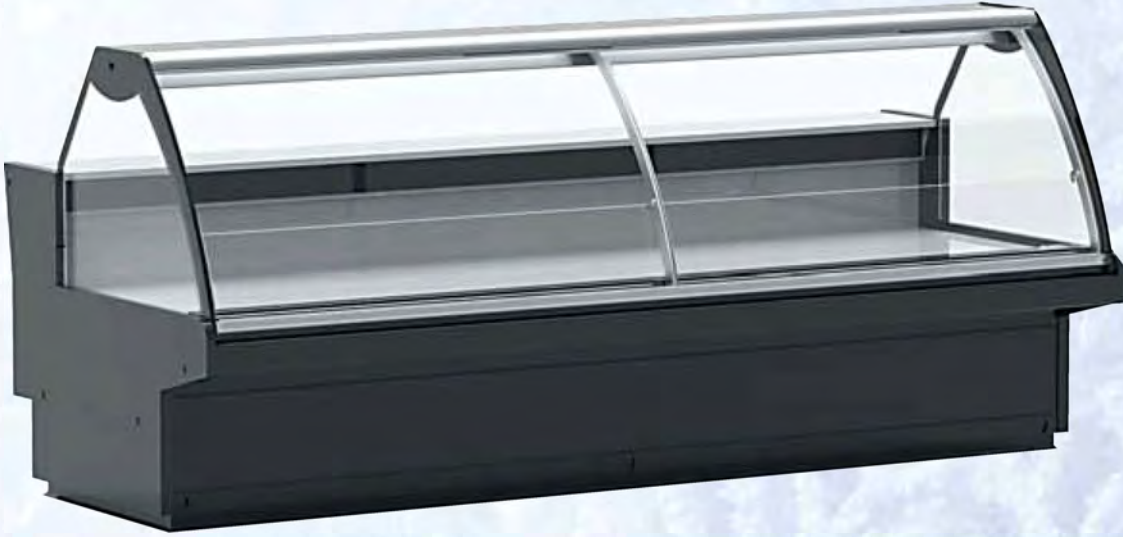

SYDNEY BA.CG

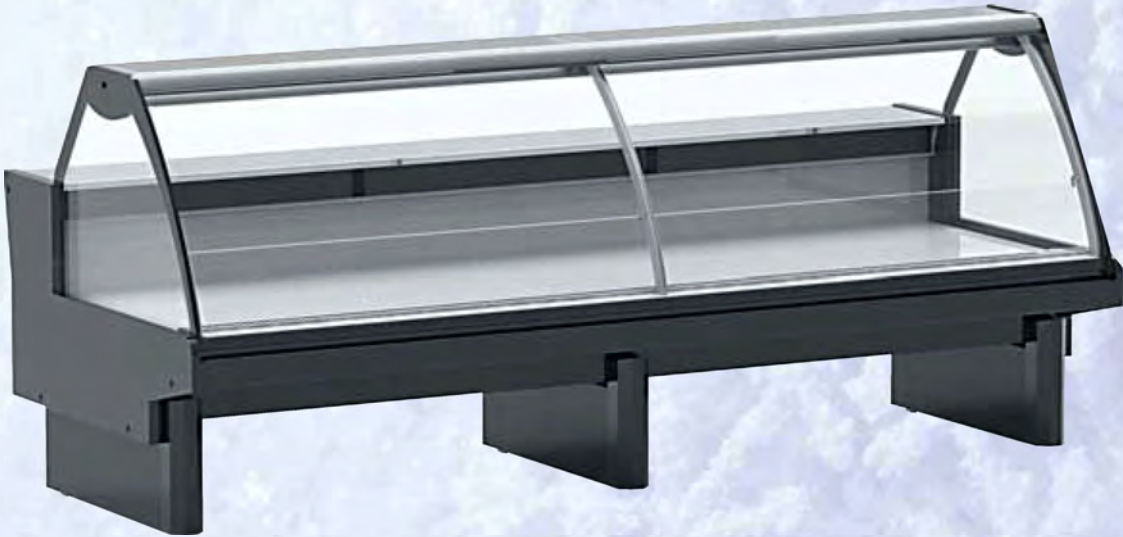

modules 0.938 1.25 1.875 2.500 2.812 3.124 3.750

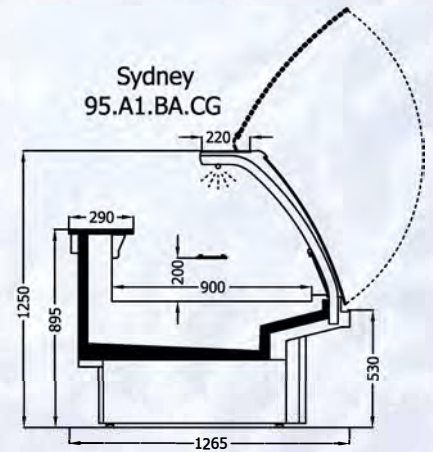
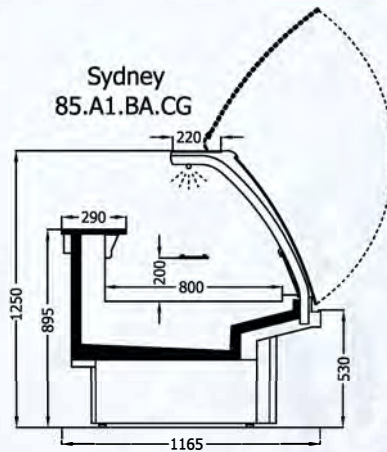
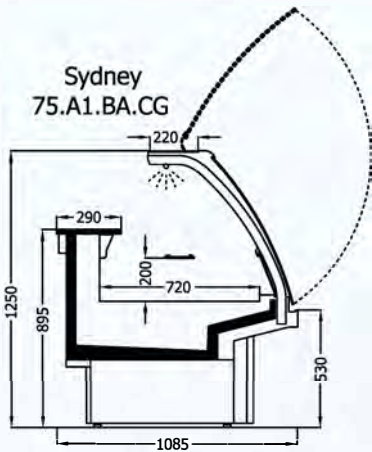
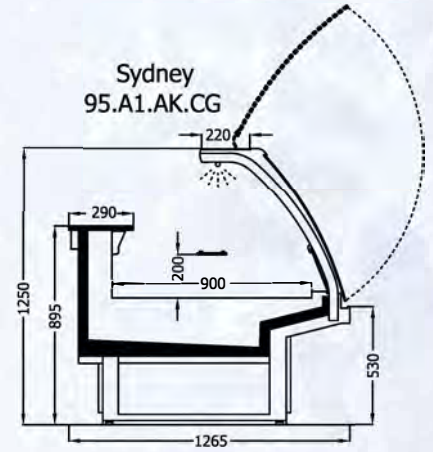
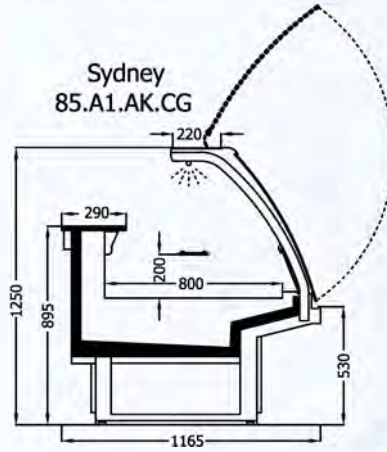
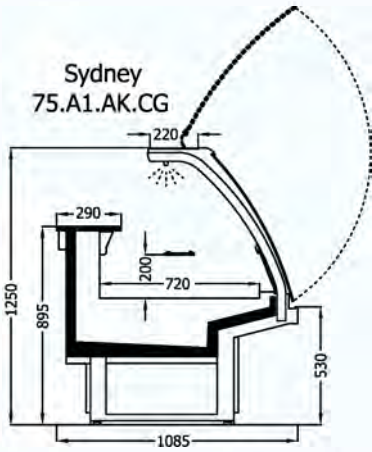

Sydney 85.A1 ICC 90°

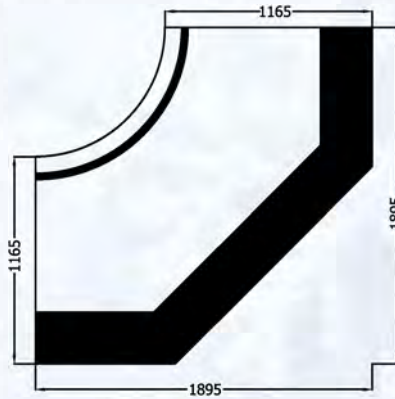

Sydney 95.A1 ICC 90°

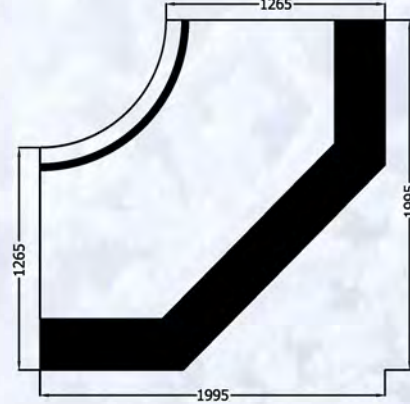

Sydney 85.A1 OCC 90°

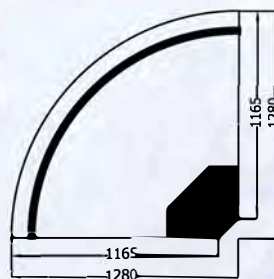

Sydney 95.A1 OCC 90°

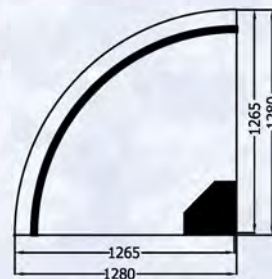

## SYDNEY FG

DIŐTAN MOTORLU | REMOTE

SYDNEY AK.FG



SYDNEY BA.FG

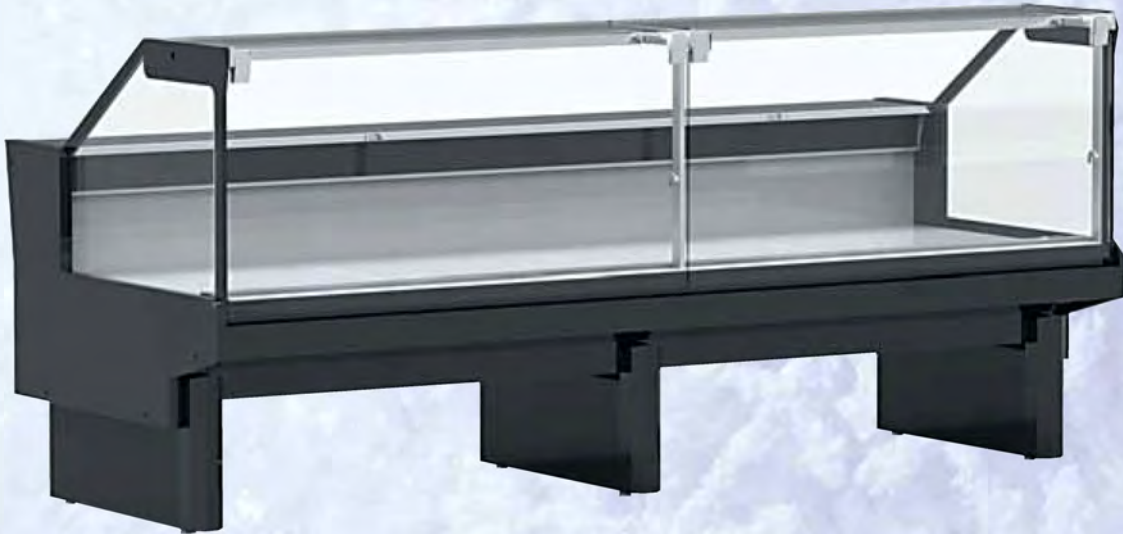

modules 0.938 1.25 1.875 2.500 2.812 3.124 3.750

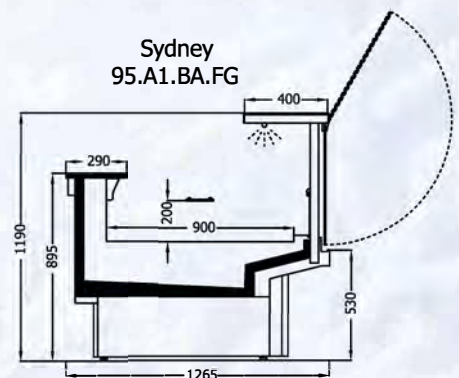
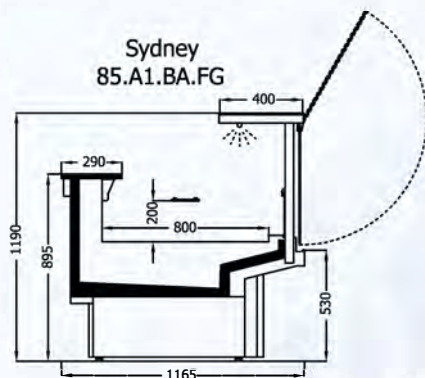
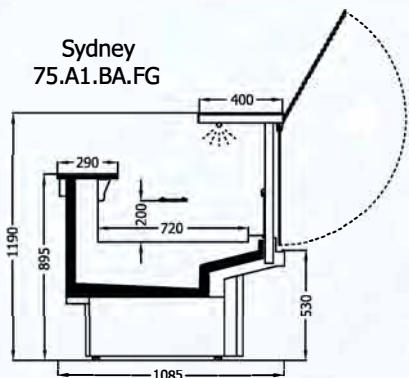
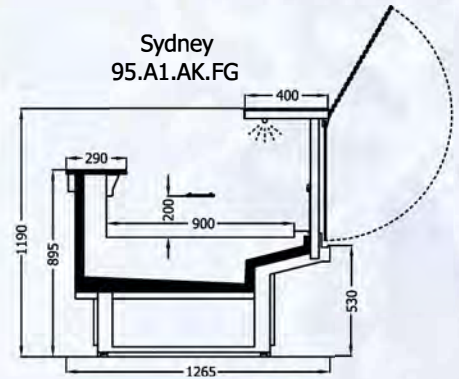
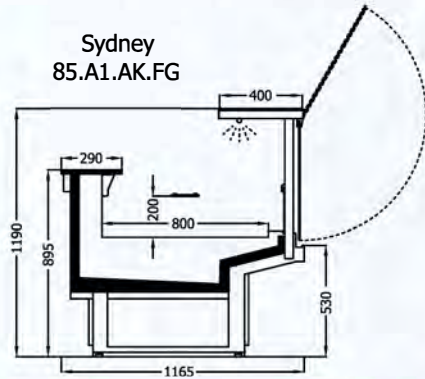
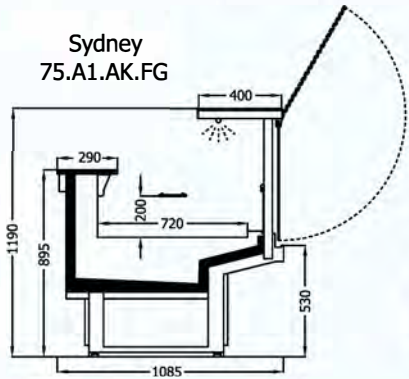

Sydney 85.A1 ICC 90°

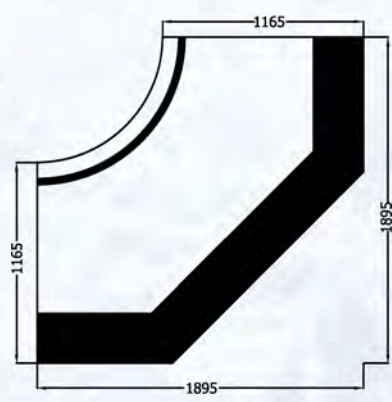

Sydney 95.A1 ICC 90°

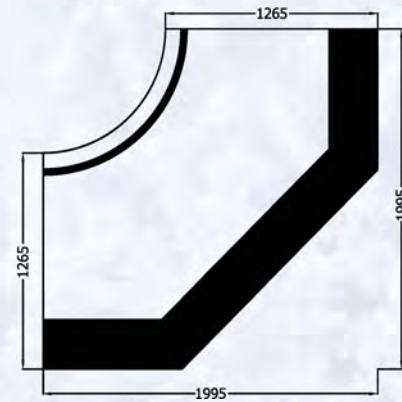

Sydney 85.A1 OCC 90°

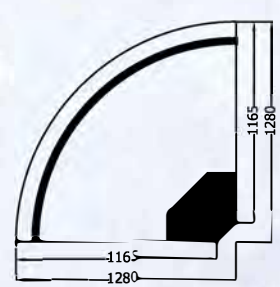

Sydney 95.A1 OCC 90°

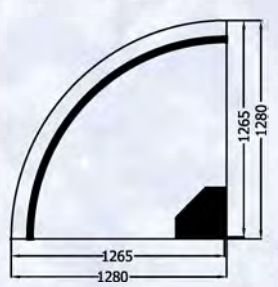

## SYDNEY AFG

DIŐTAN MOTORLU | REMOTE

SYDNEY AK.AFG

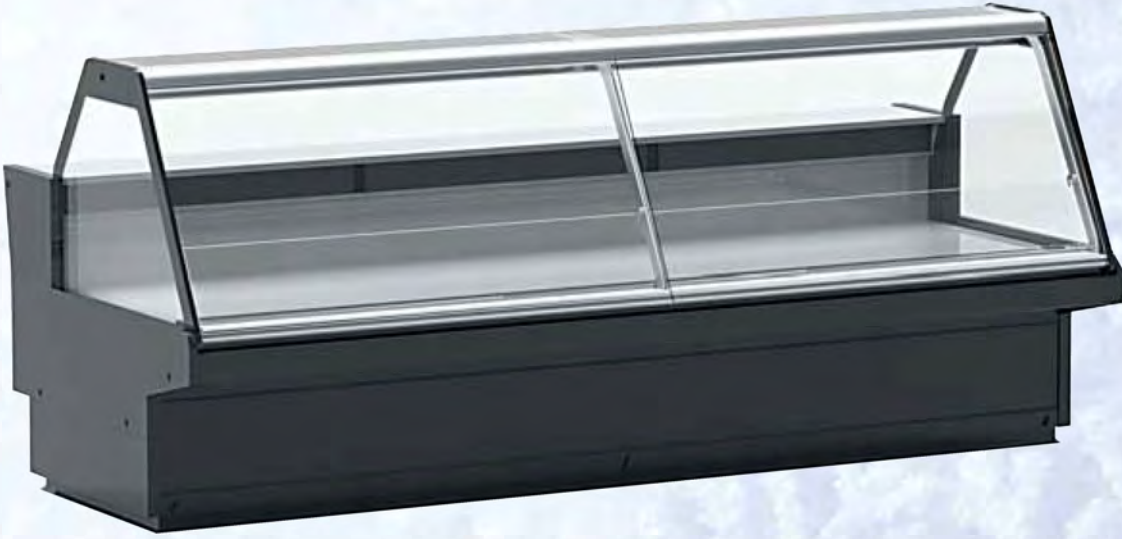

SYDNEY BA.AFG



modules 0.938 1.25 1.875 2.500 2.812 3.124 3.750

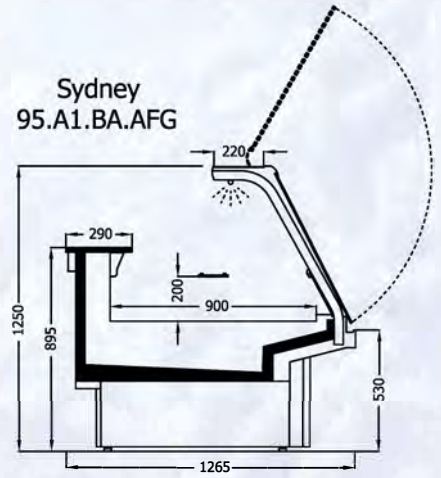
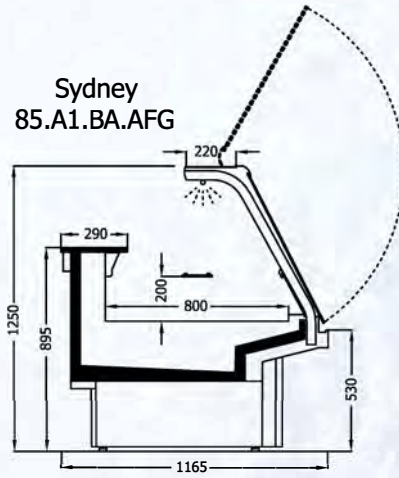
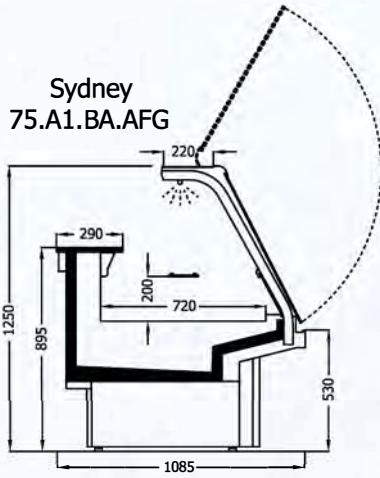
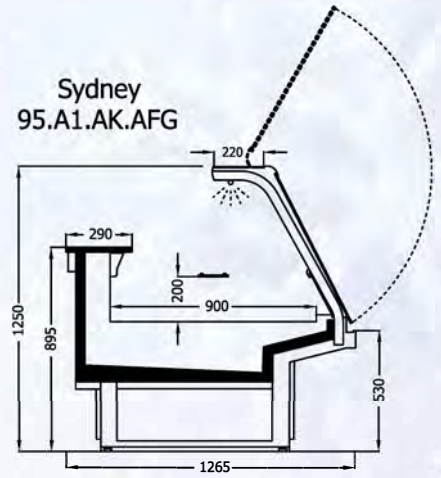
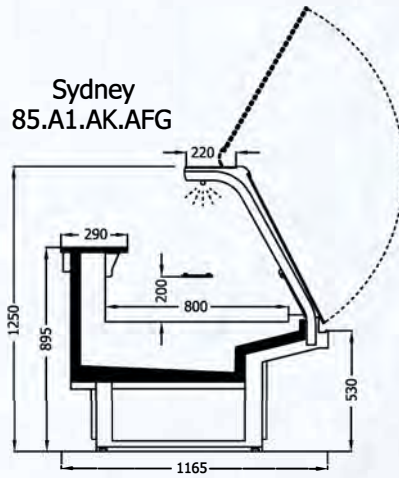
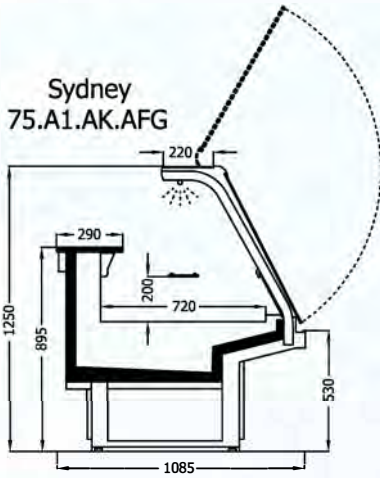

Sydney 85.A1 ICC 90°

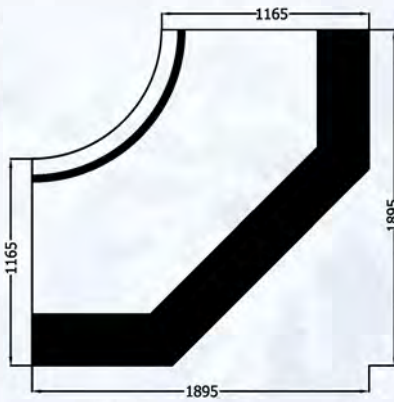

Sydney 95.A1 ICC 90°

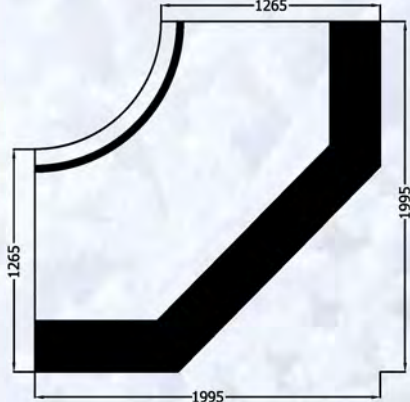

Sydney 85.A1 OCC 90°

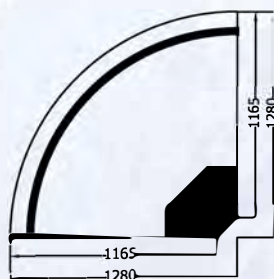

Sydney 95.A1 OCC 90°

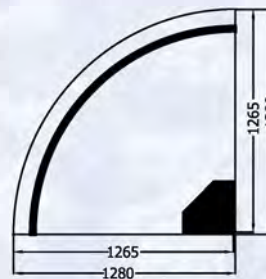

## SYDNEY SS.CG

DIŐTAN MOTORLU | REMOTE

SYDNEY AK.SS.CG

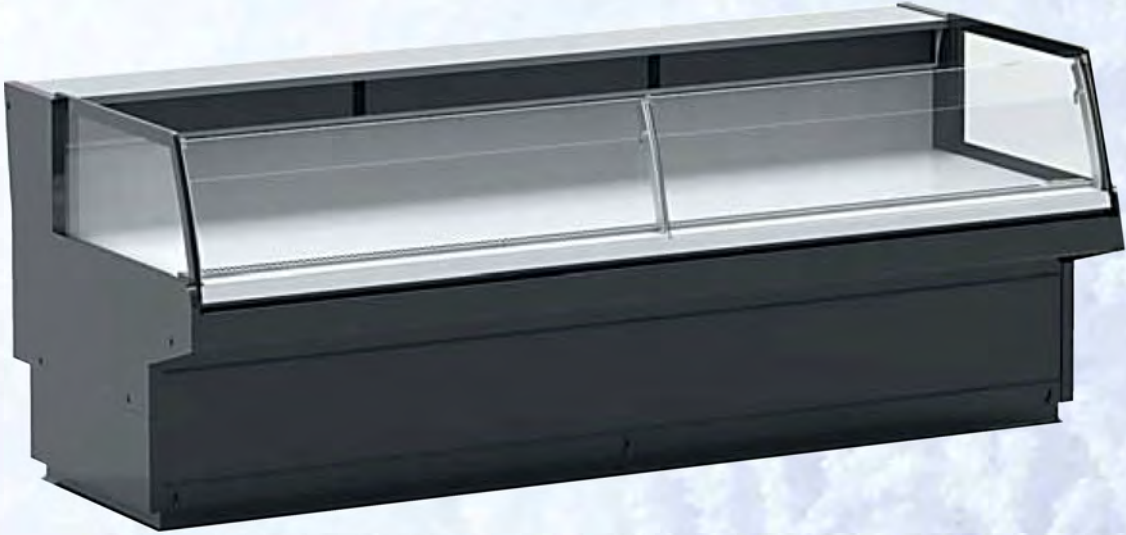

SYDNEY BA.SS.CG

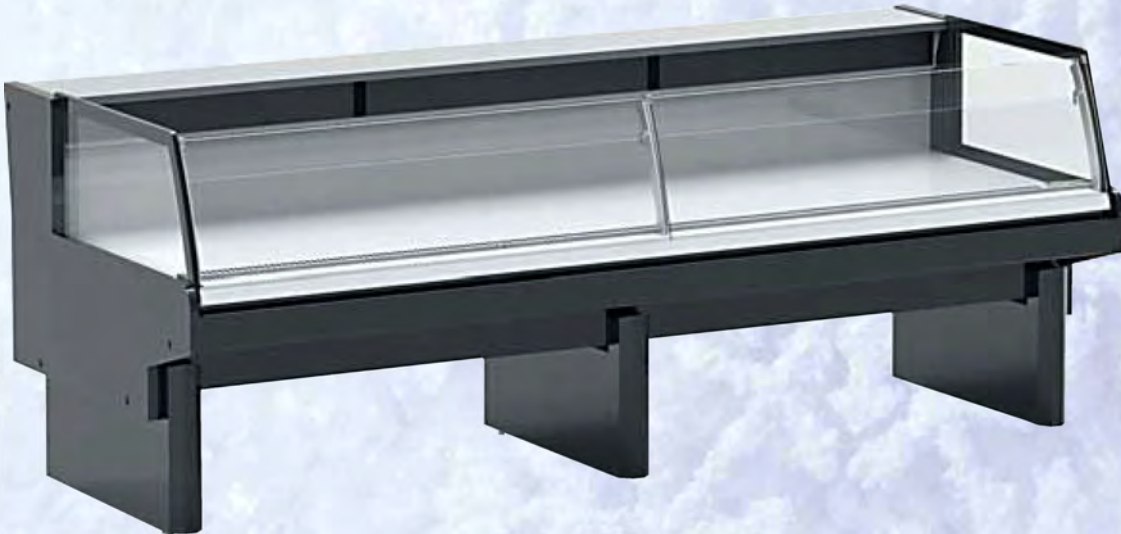

modules 0.938 1.25 1.875 2.500 2.812 3.124 3.750

Sydney  
75.A1.AK.SS.CG

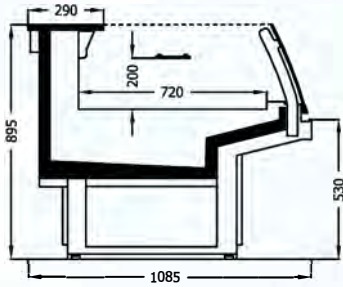

Sydney  
85.A1.AK.SS.CG

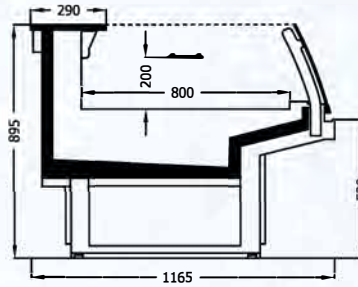

Sydney  
95.A1.AK.SS.CG

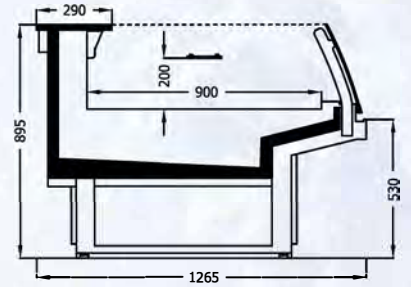

Sydney  
75.A1.BA.SS.CG

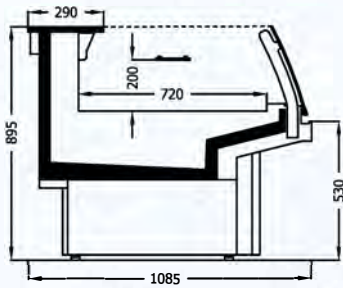

Sydney  
85.A1.BA.SS.CG

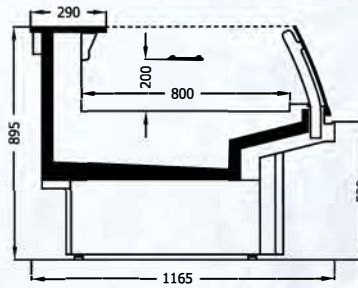

Sydney  
95.A1.BA.SS.CG

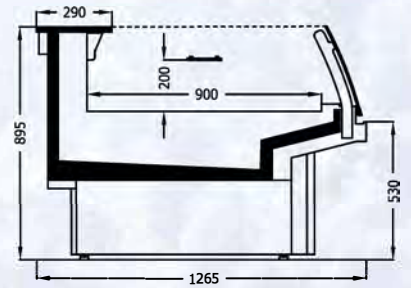

Sydney 85.A1 ICC 90°

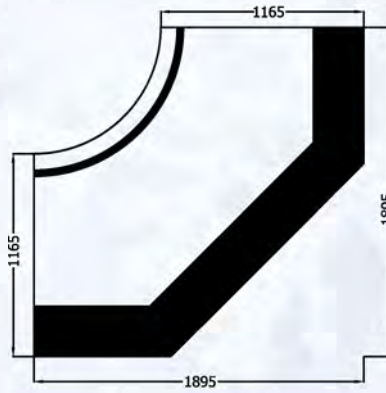

Sydney 95.A1 ICC 90°

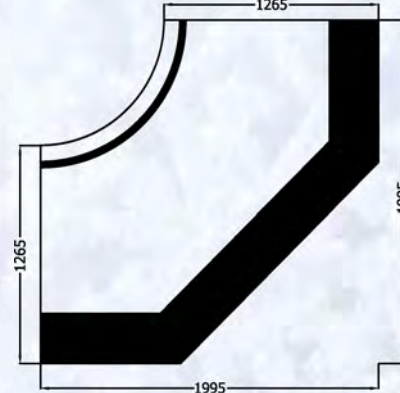

Sydney 85.A1 OCC 90°

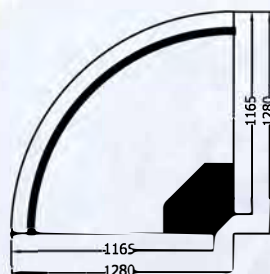

Sydney 95.A1 OCC 90°

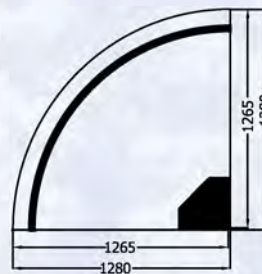



# SYDNEY SS.FG

DIŐTAN MOTORLU | REMOTE

SYDNEY AK.SS.FG

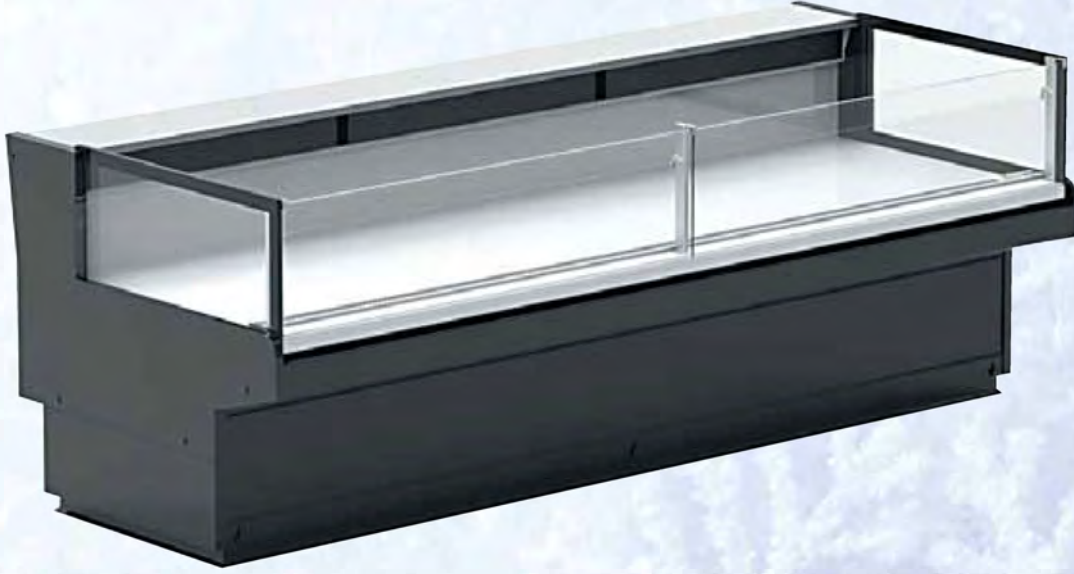

SYDNEY BA.SS.FG



modules 0.938 1.25 1.875 2.500 2.812 3.124 3.750

Sydney  
75.A1.AK.SS.FG

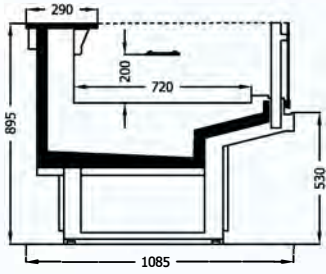

Sydney  
85.A1.AK.SS.FG

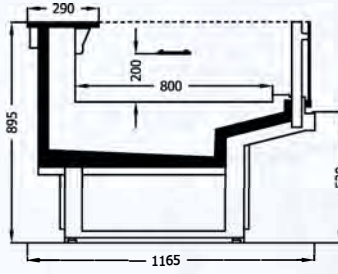

Sydney  
95.A1.AK.SS.FG

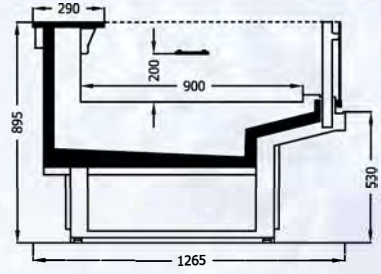

Sydney  
75.A1.BA.SS.FG

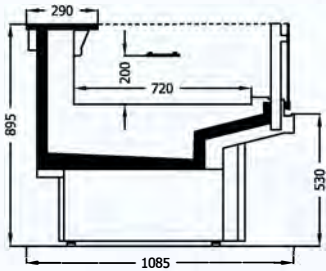

Sydney  
85.A1.BA.SS.FG

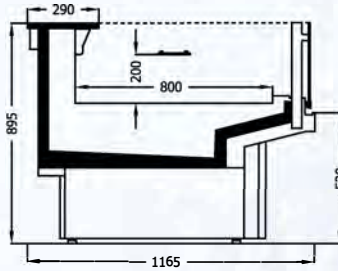

Sydney  
95.A1.BA.SS.FG

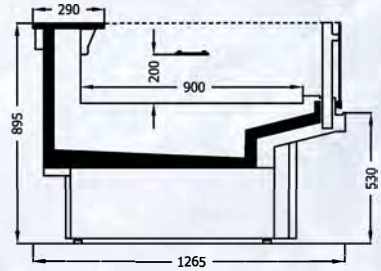

Sydney 85.A1 ICC 90°

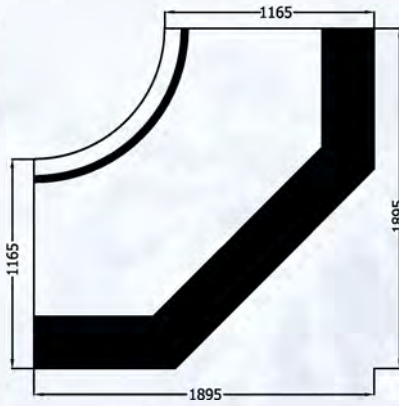

Sydney 95.A1 ICC 90°

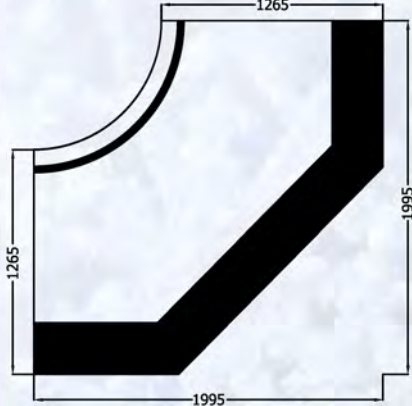

Sydney 85.A1 OCC 90°

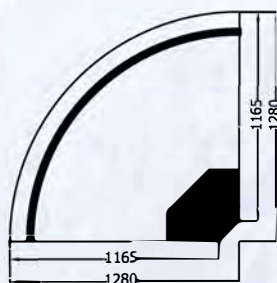

Sydney 95.A1 OCC 90°

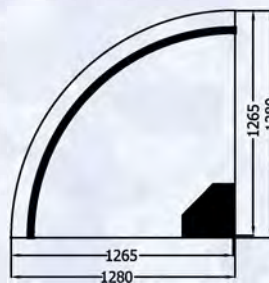

# SALTA FG

DIŐTAN MOTORLU | REMOTE

SALTA AK.FG



SALTA BA.FG



modules 0.938 1.25 1.875 2.500 2.812 3.124 3.750

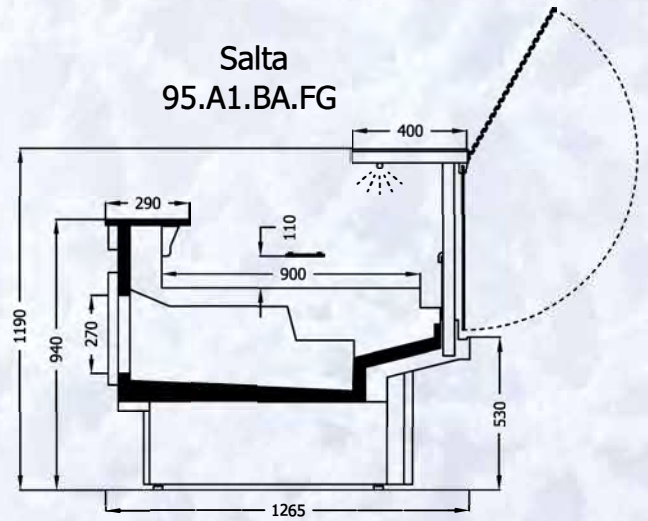
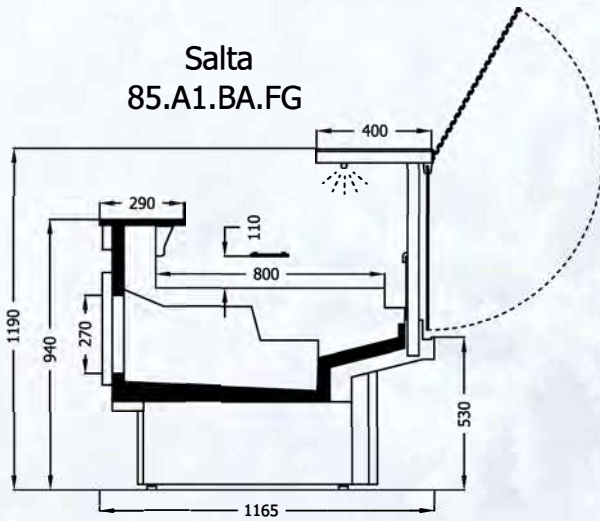
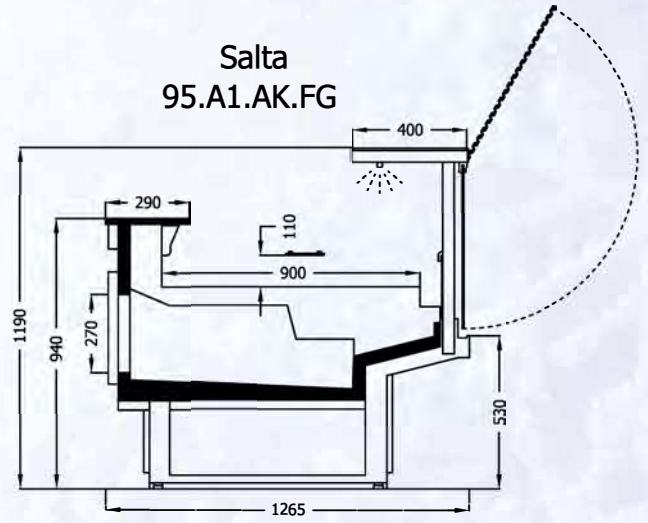
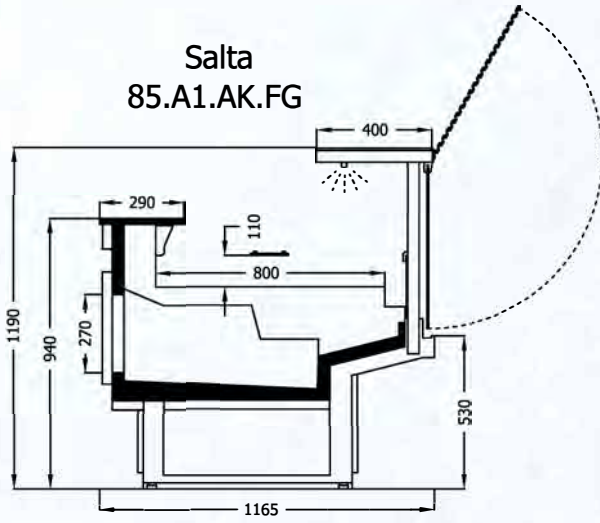

SÜTLÜK | MULTI DECKS



DIŐTAN MOTORLU | REMOTE



# MELBOURNE

DIŐTAN MOTORLU | REMOTE



modules 0.938 1.25 1.875 2.500 2.812 3.124 3.750

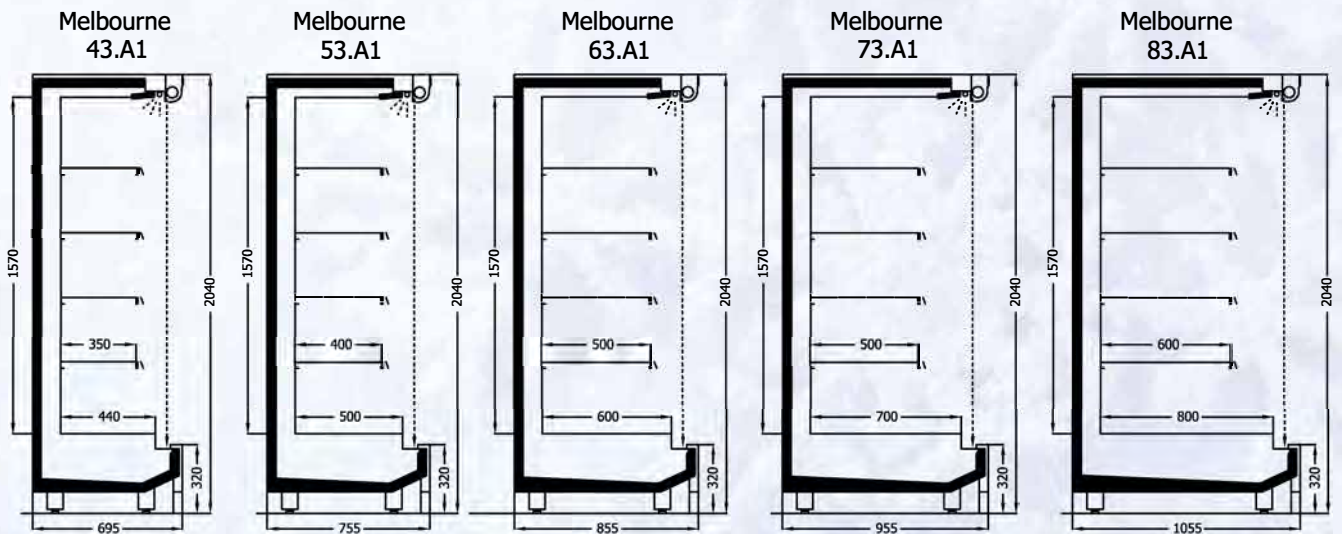
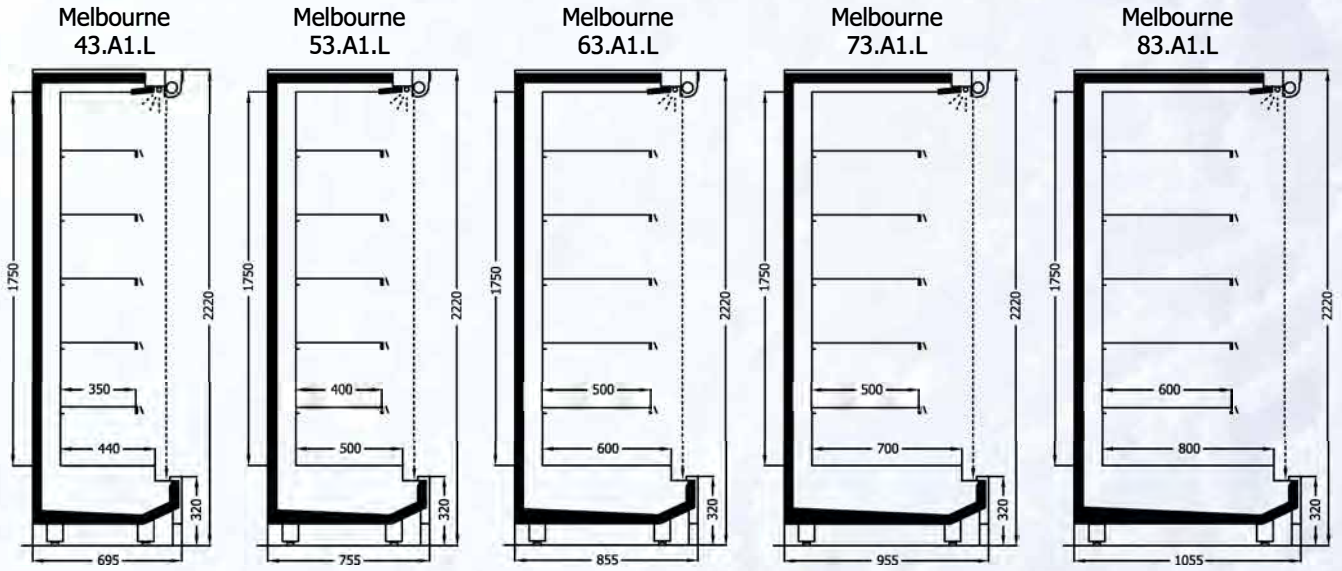



# MELBOURNE DGD

DIŐTAN MOTORLU | REMOTE



modules 0.938 1.25 1.875 2.500 2.812 3.124 3.750

Melbourne 43.A1.L.DGD

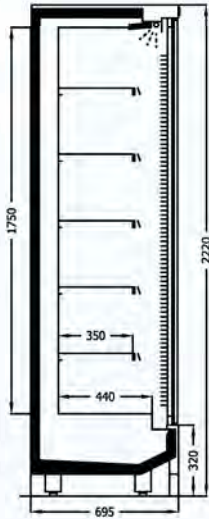

Melbourne 53.A1.L.DGD

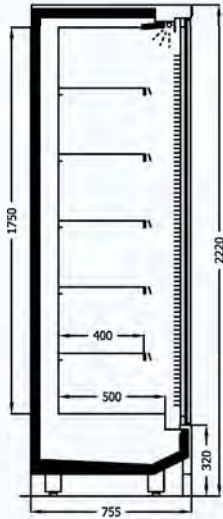

Melbourne 63.A1.L.DGD

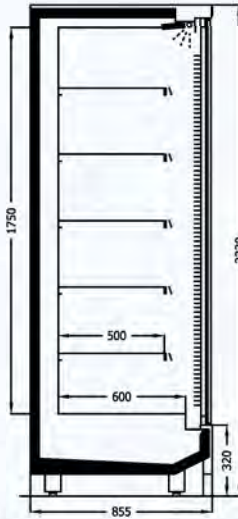

Melbourne 73.A1.L.DGD

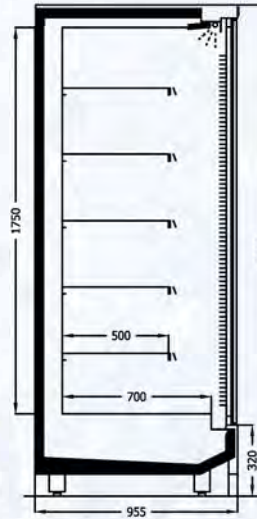

Melbourne 83.A1.L.DGD

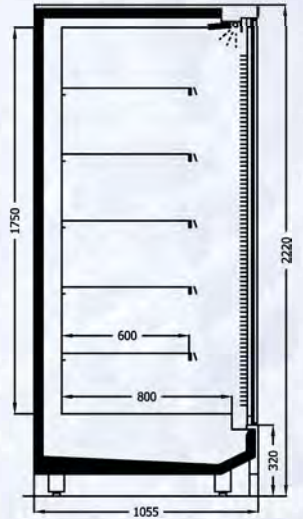

Melbourne 43.A1.DGD

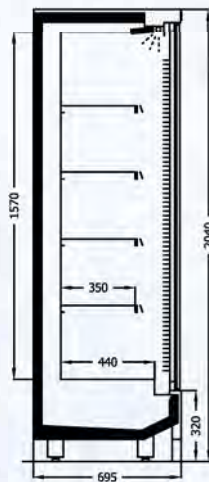

Melbourne 53.A1.DGD

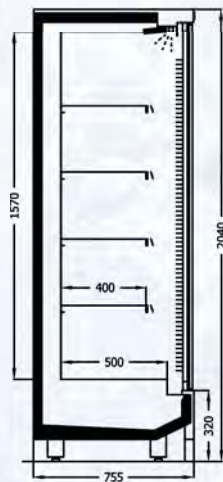

Melbourne 63.A1.DGD

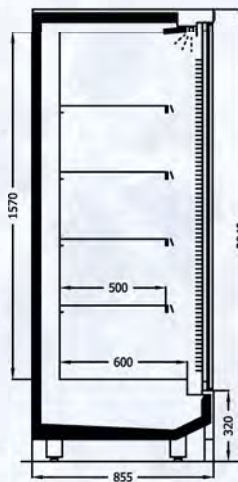

Melbourne 73.A1.DGD

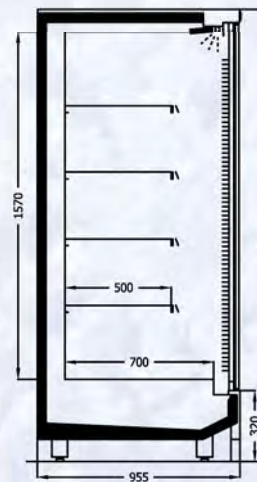

Melbourne 83.A1.DGD

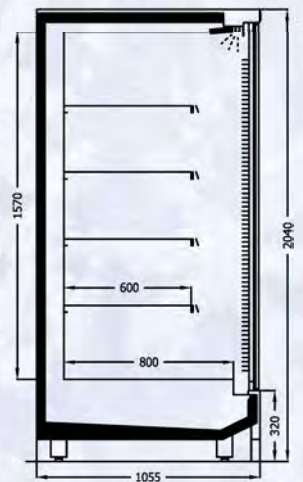

# MELBOURNE D-SGD

DIŐTAN MOTORLU | REMOTE



modules 0.938 1.25 1.875 2.500 2.812 3.124 3.750

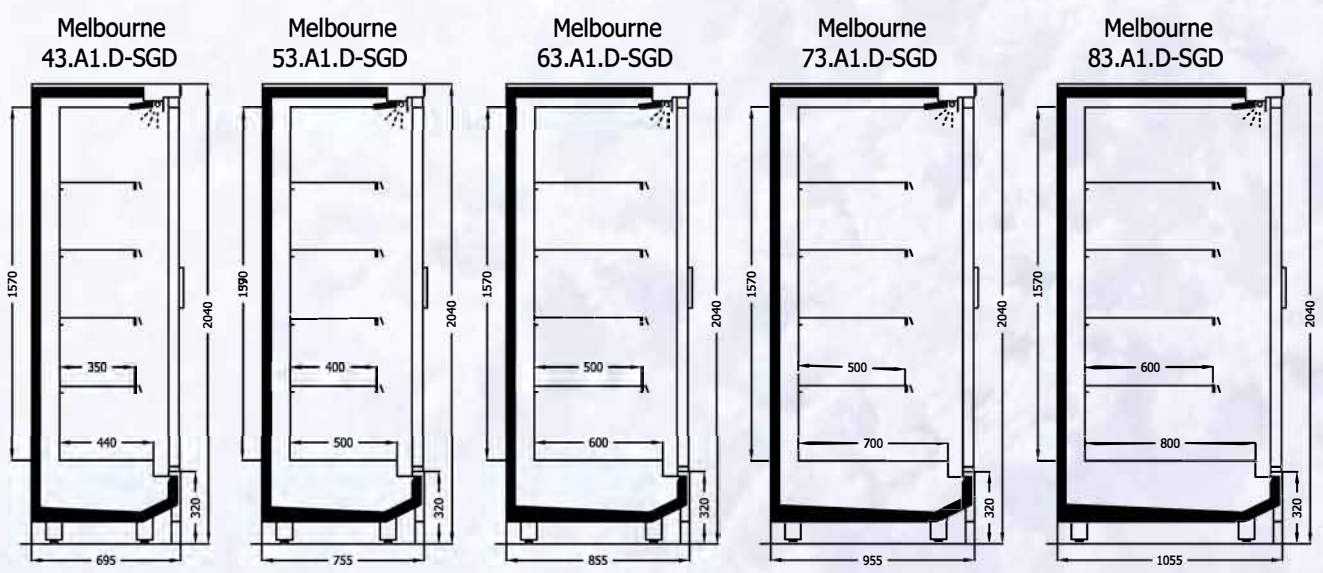
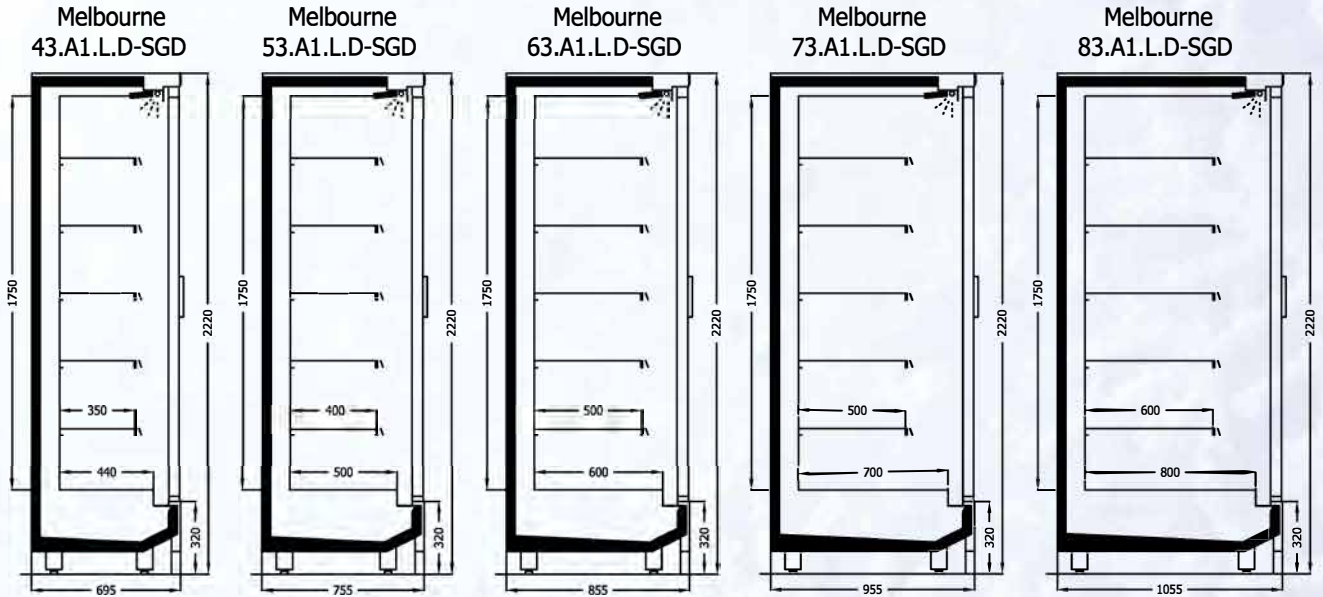

# MELBOURNE OGD

DIŐTAN MOTORLU | REMOTE

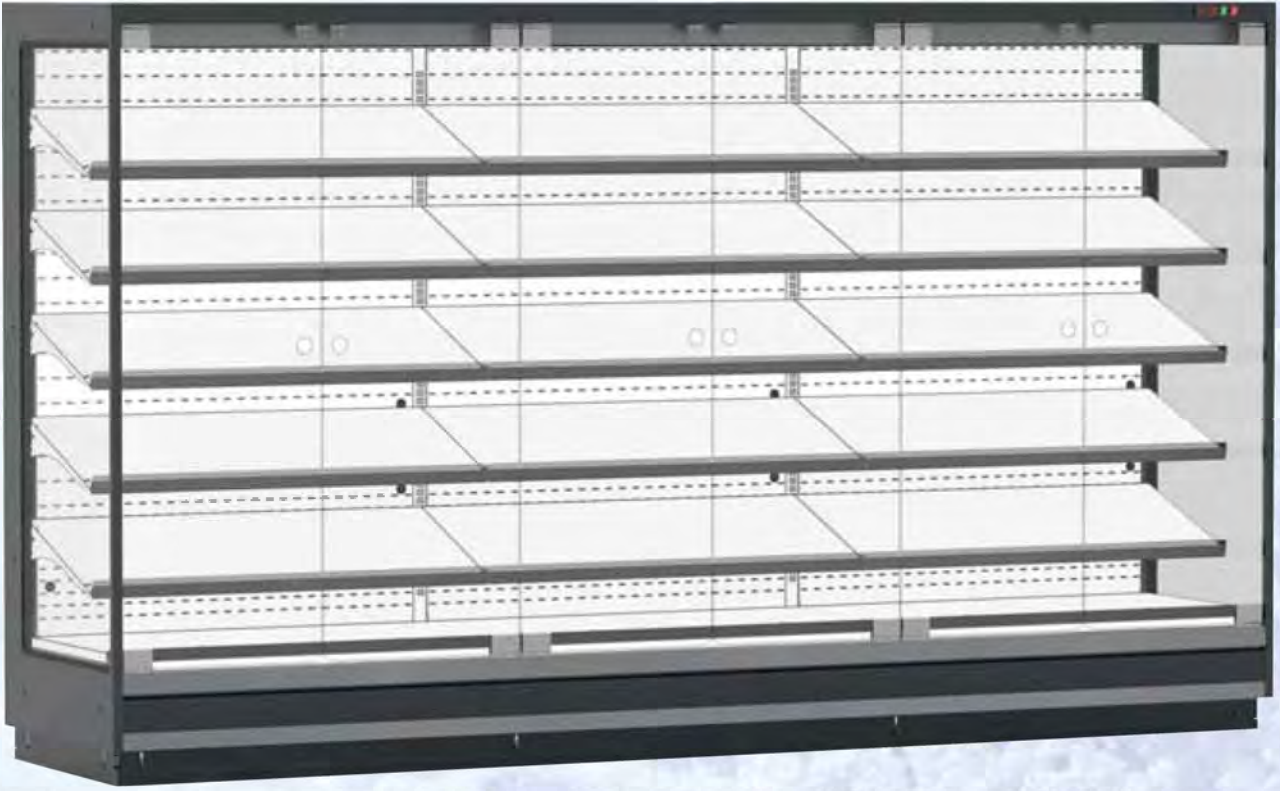

modules 0.938 1.25 1.875 2.500 2.812 3.124 3.750

Melbourne  
43.A1.L.OGD

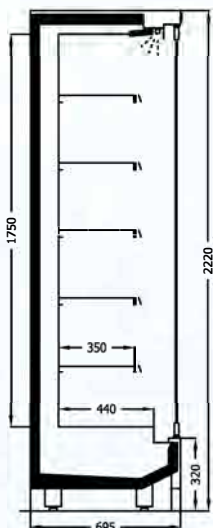

Melbourne  
53.A1.L.OGD

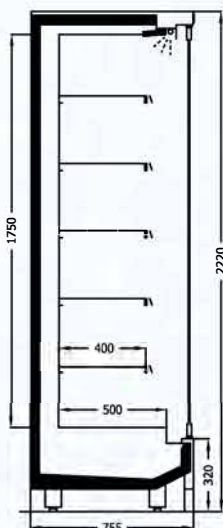

Melbourne  
63.A1.L.OGD

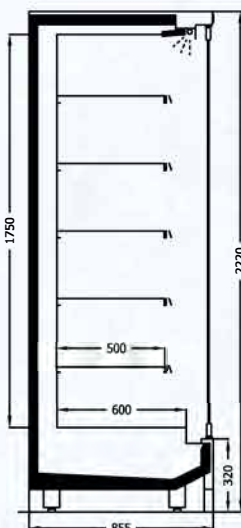

Melbourne  
73.A1.L.OGD

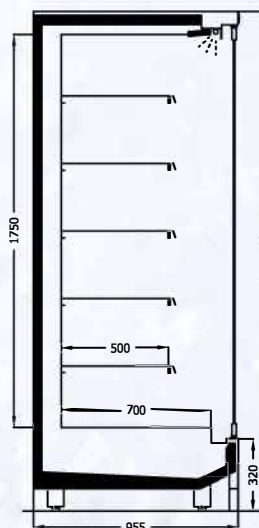

Melbourne  
83.A1.L.OGD

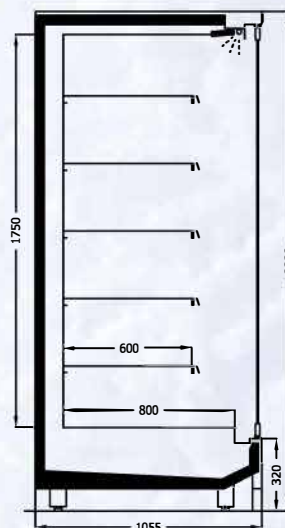

Melbourne  
43.A1.OGD

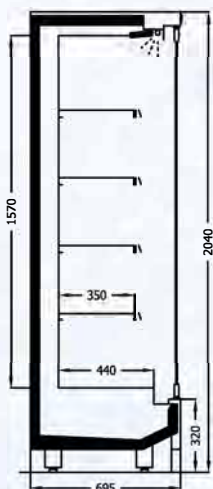

Melbourne  
53.A1.OGD

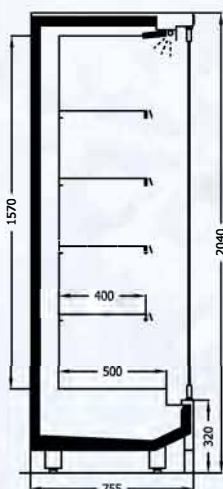

Melbourne  
63.A1.OGD

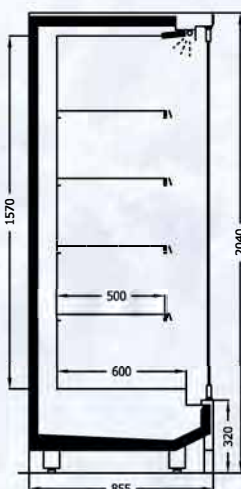

Melbourne  
73.A1.OGD

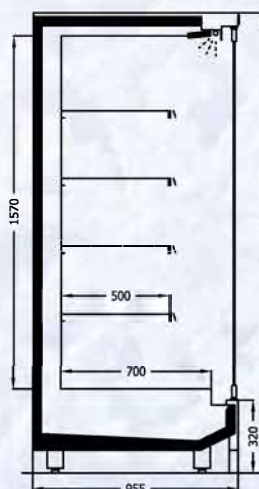

Melbourne  
83.A1.OGD

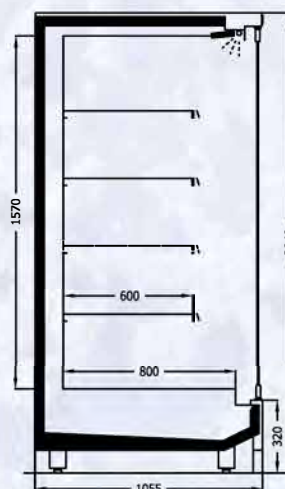

# MELBOURNE HB

DIŐTAN MOTORLU | REMOTE

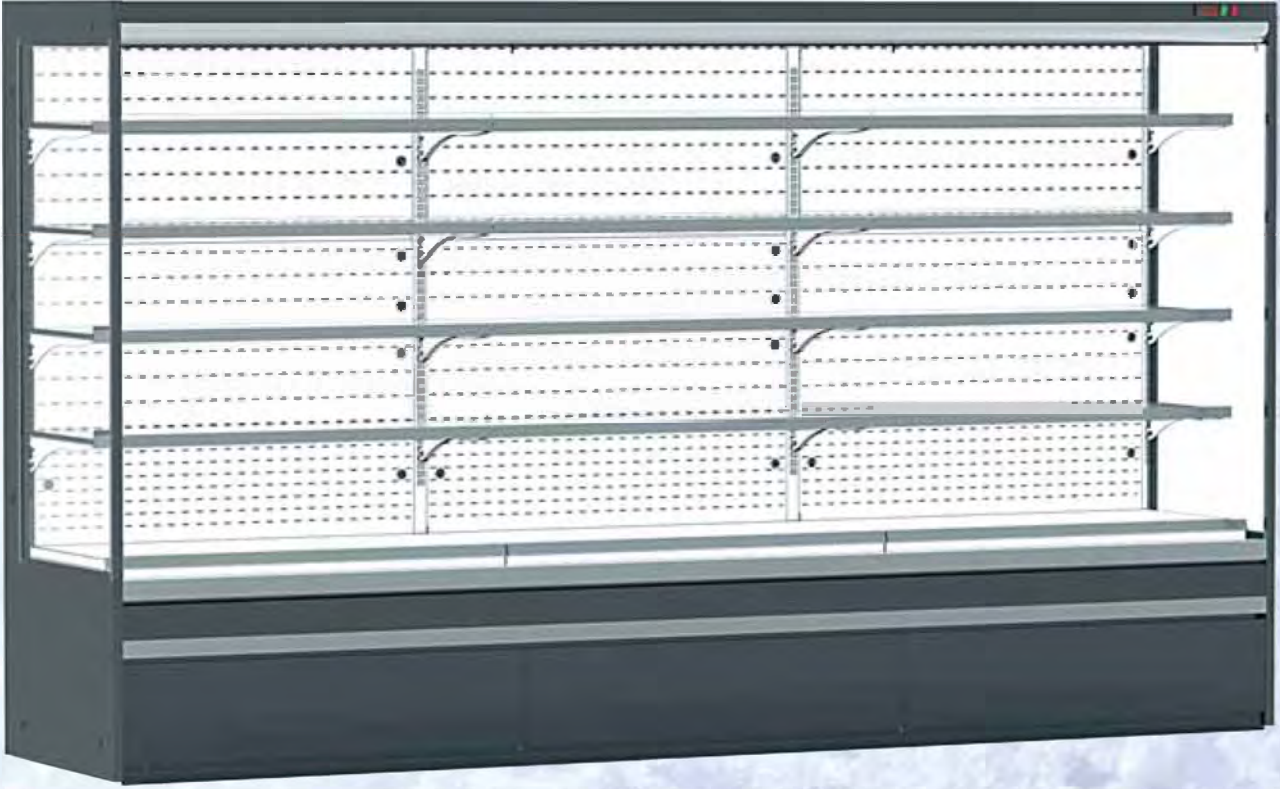

modules 0.938 1.25 1.875 2.500 2.812 3.124 3.750

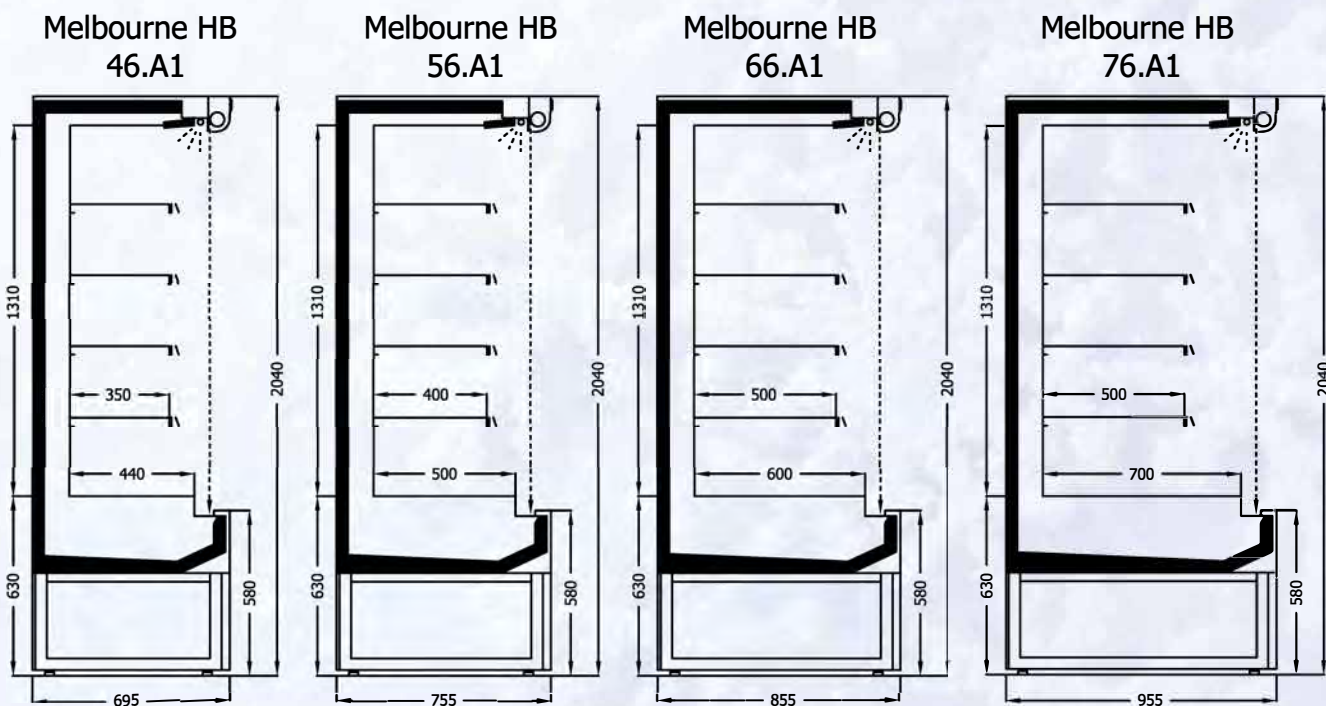
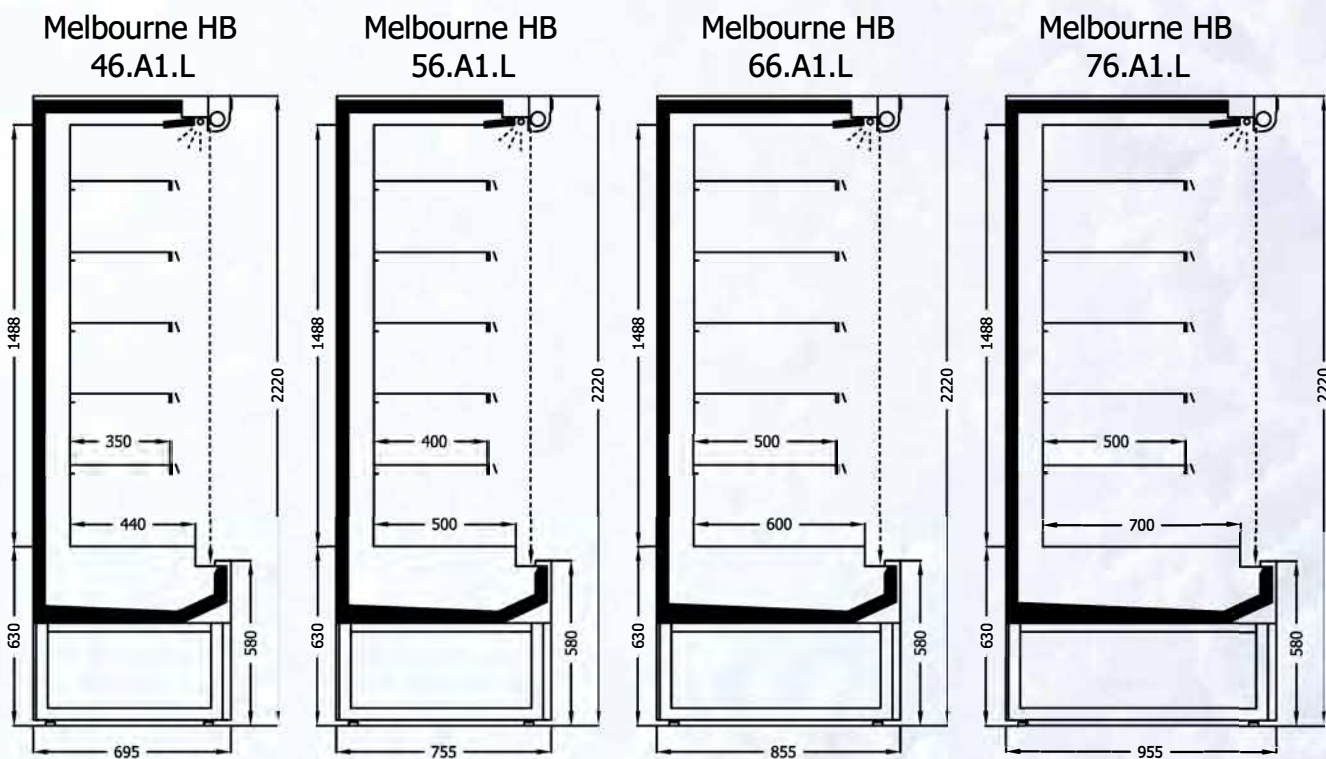



# MELBOURNE HB DGD

DIŐTAN MOTORLU | REMOTE



modules 0.938 1.25 1.875 2.500 2.812 3.124 3.750

Melbourne HB  
 46.A1.L.DGD

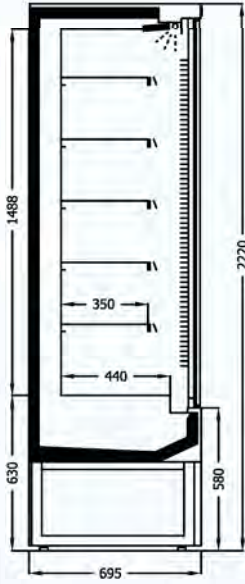

Melbourne HB  
 56.A1.L.DGD

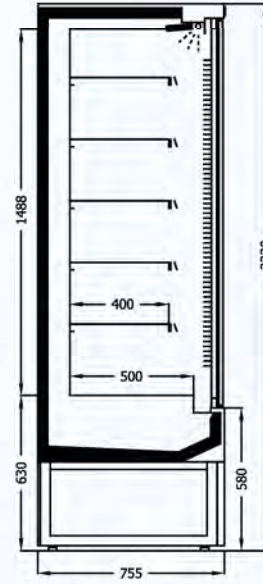

Melbourne HB  
 66.A1.L.DGD

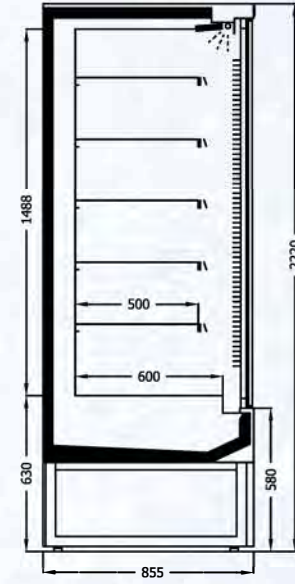

Melbourne HB  
 76.A1.L.DGD

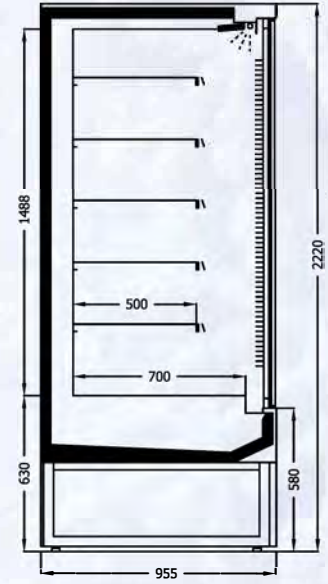

Melbourne HB  
 46.A1.DGD

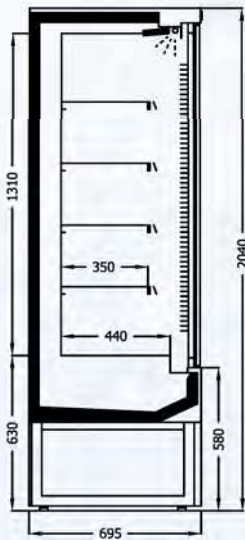

Melbourne HB  
 56.A1.DGD

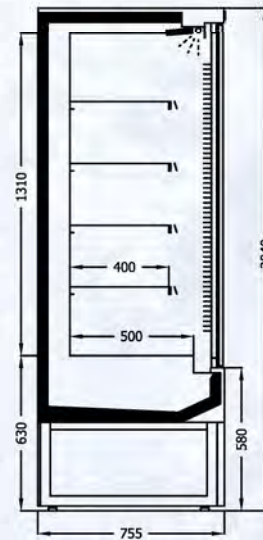

Melbourne HB  
 66.A1.DGD

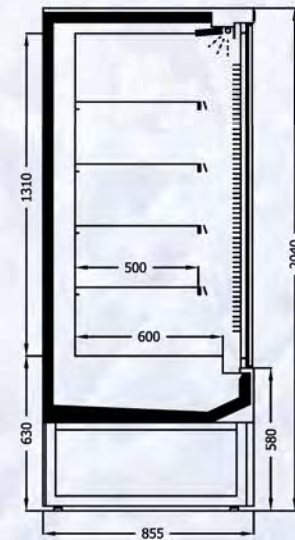

Melbourne HB  
 76.A1.DGD

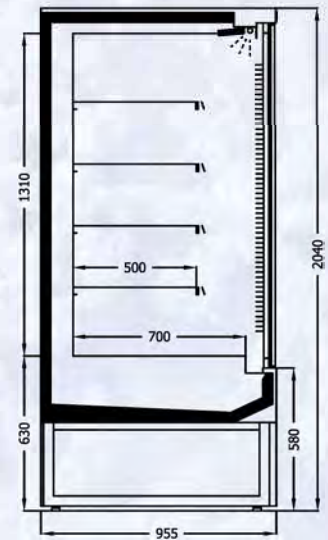

# MELBOURNE HB D-SGD

DIŐTAN MOTORLU | REMOTE

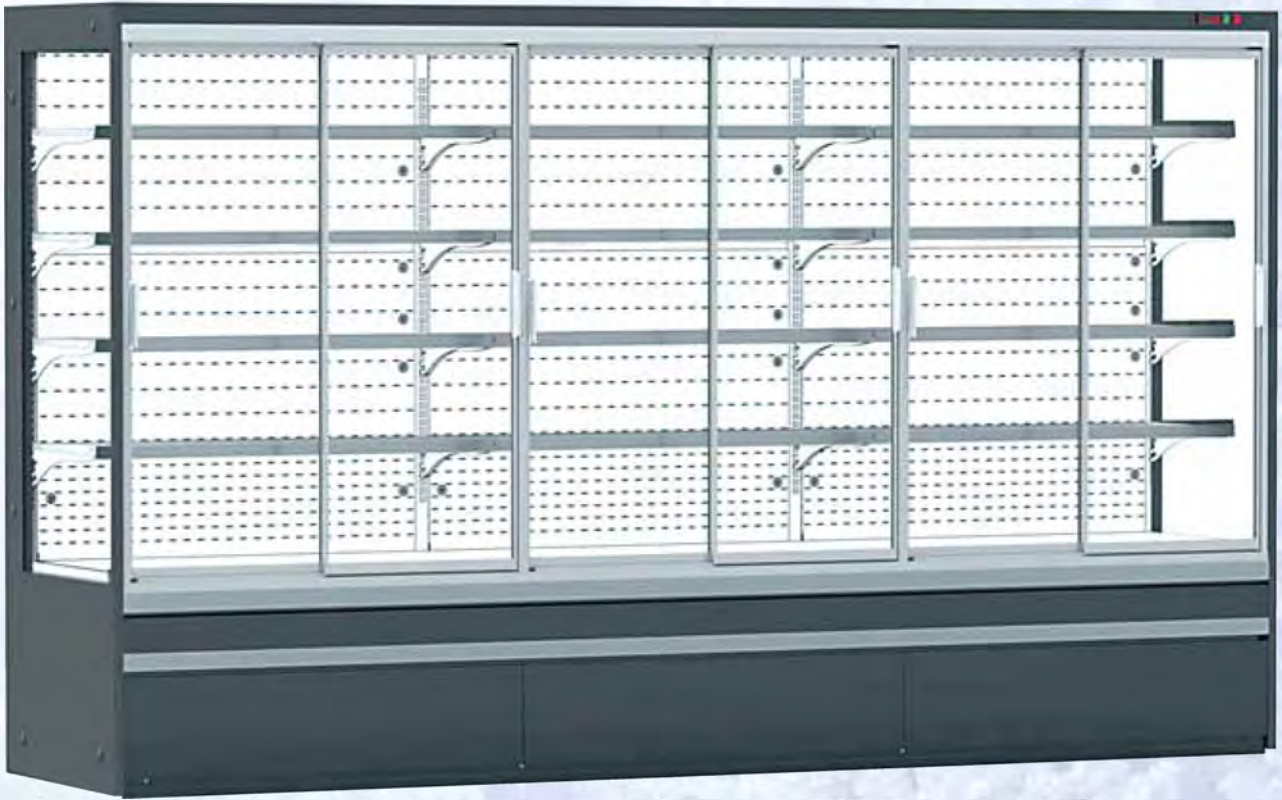

modules 0.938 1.25 1.875 2.500 2.812 3.124 3.750

Melbourne HB  
46.A1.L.D-SGD

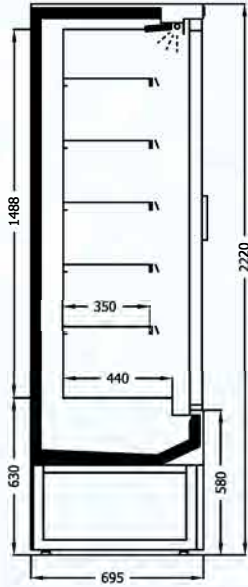

Melbourne HB  
56.A1.L.D-SGD

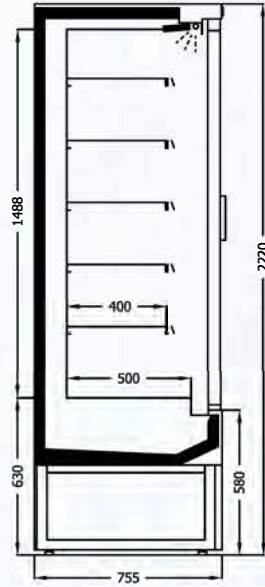

Melbourne HB  
66.A1.L.D-SGD

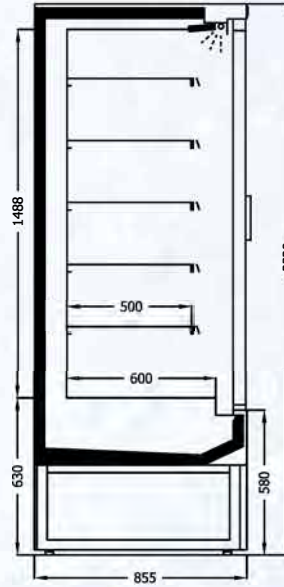

Melbourne HB  
76.A1.L.D-SGD

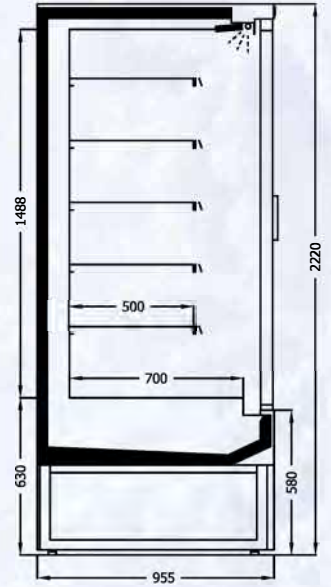

Melbourne HB  
46.A1.D-SGD

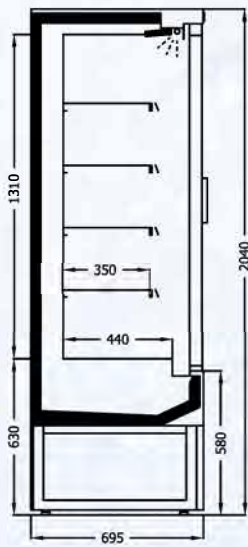

Melbourne HB  
56.A1.D-SGD

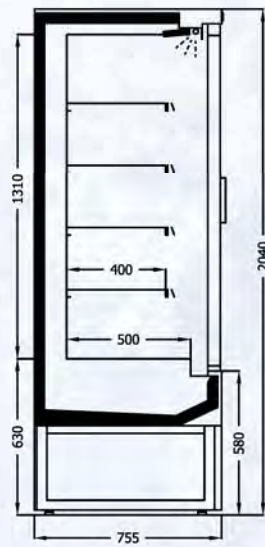

Melbourne HB  
66.A1.D-SGD

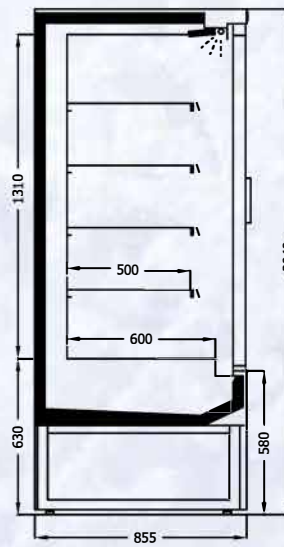

Melbourne HB  
76.A1.D-SGD

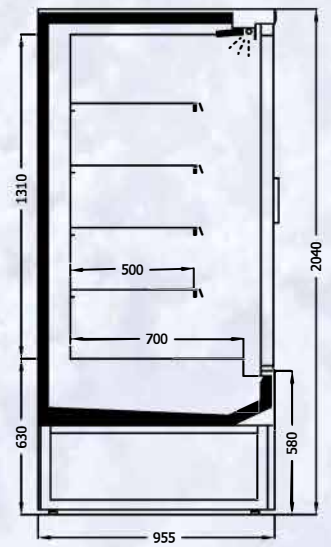

# MELBOURNE HB D-OGD

DIŐTAN MOTORLU | REMOTE

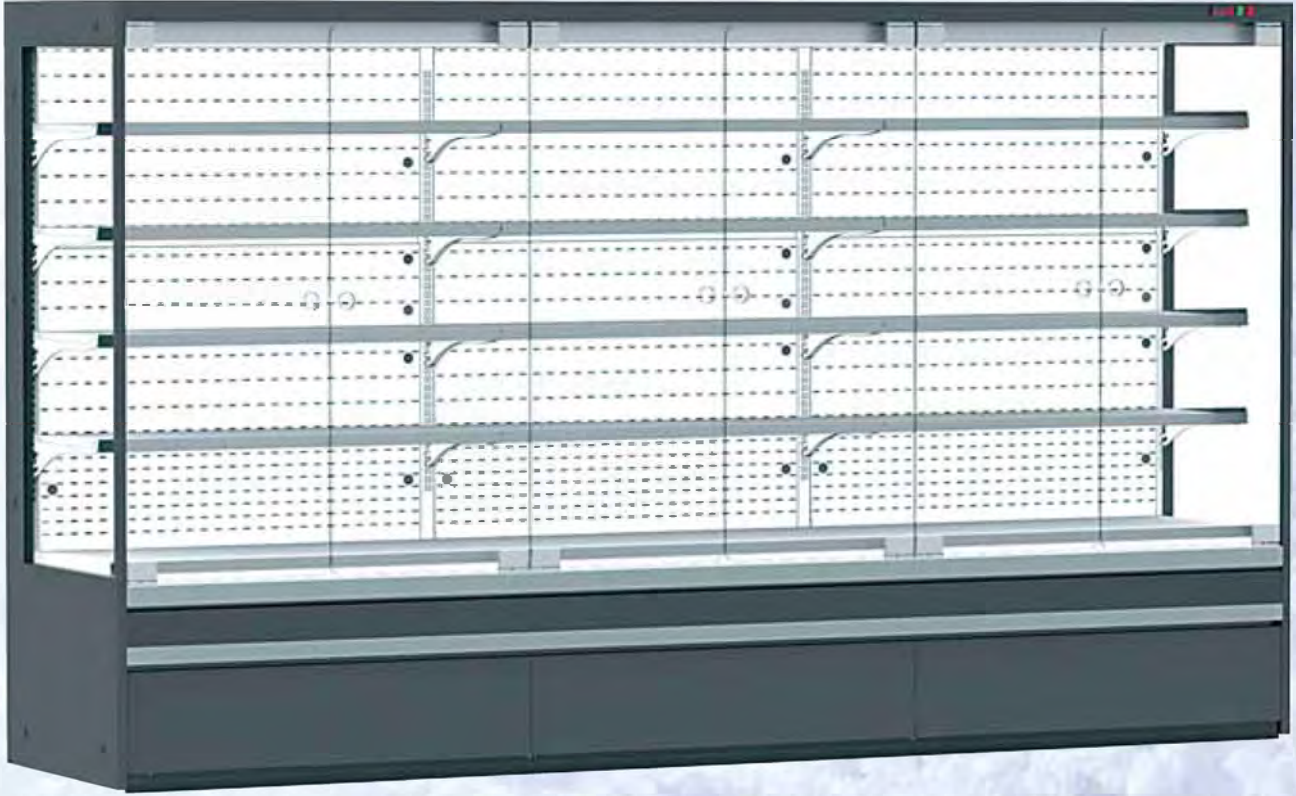

modules 0.938 1.25 1.875 2.500 2.812 3.124 3.750

Melbourne HB  
46.A1.L.OGD

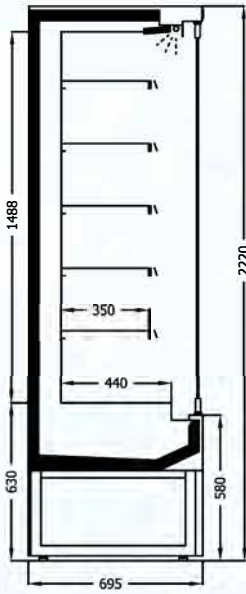

Melbourne HB  
56.A1.L.OGD

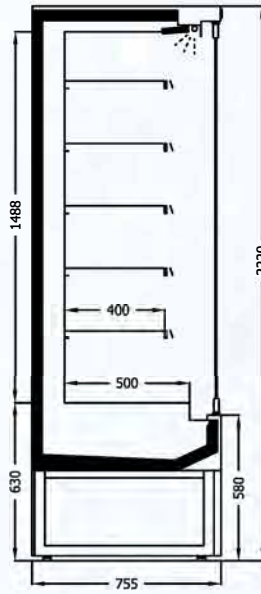

Melbourne HB  
66.A1.L.OGD

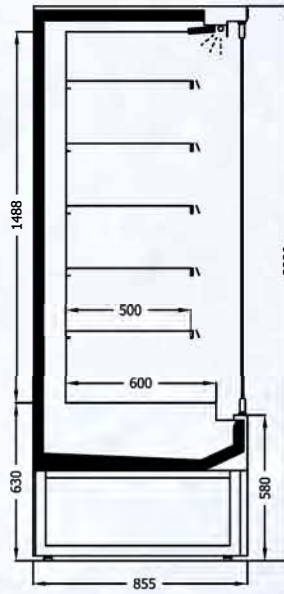

Melbourne HB  
76.A1.L.OGD

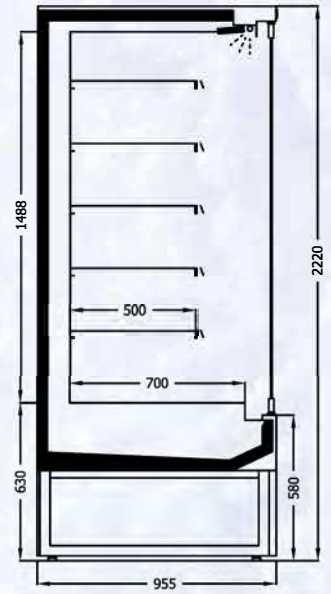

Melbourne HB  
46.A1.OGD

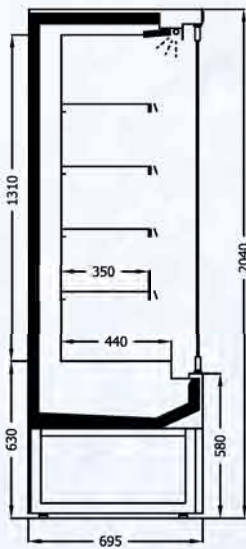

Melbourne HB  
56.A1.OGD

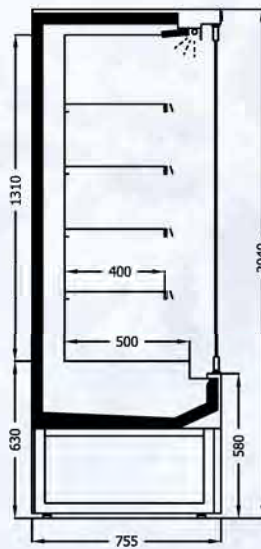

Melbourne HB  
66.A1.OGD

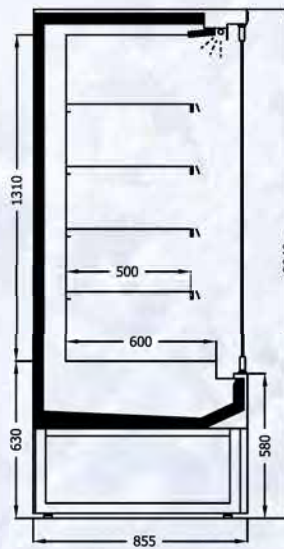

Melbourne HB  
76.A1.OGD

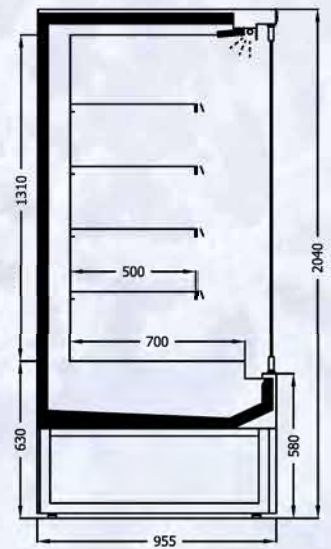

# MELBOURNE WB

DIŐTAN MOTORLU | REMOTE

MELBOURNE WB



MELBOURNE WB O-SGD



modules 1.25 1.875 2.500 3.750

Melbourne WB  
58.A1.L

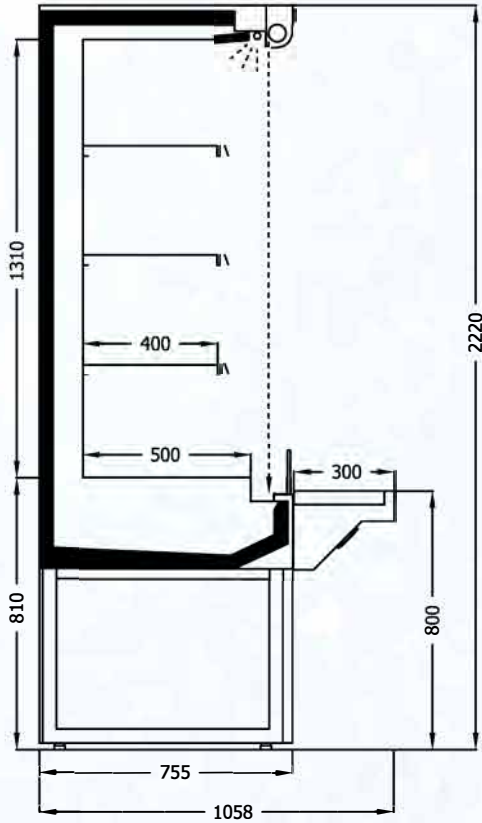

Melbourne WB  
68.A1.L

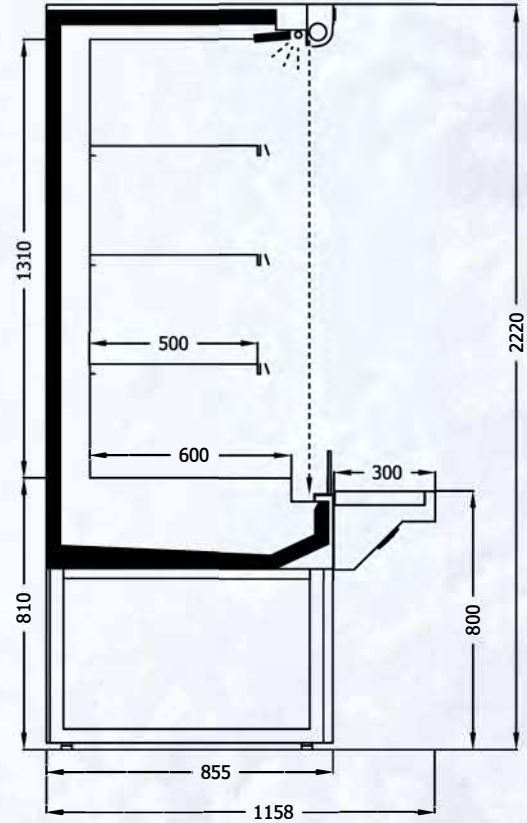

Melbourne WB  
58.A1.L.O-SGD

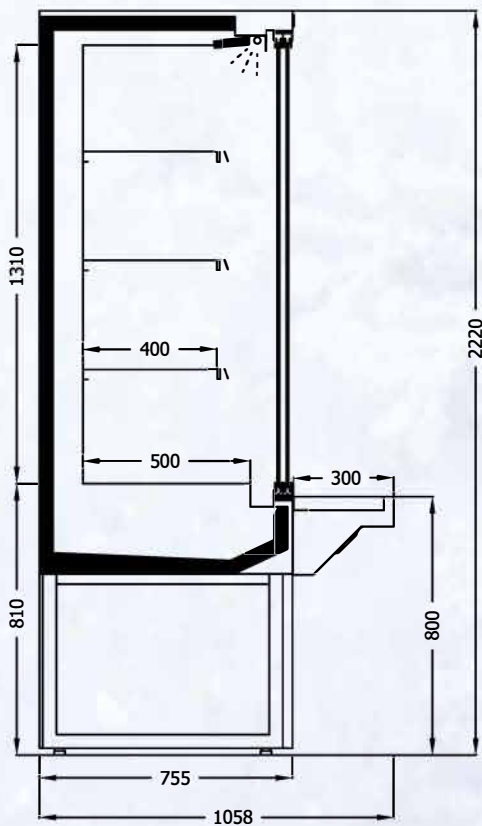

Melbourne WB  
68.A1.L.O-SGD

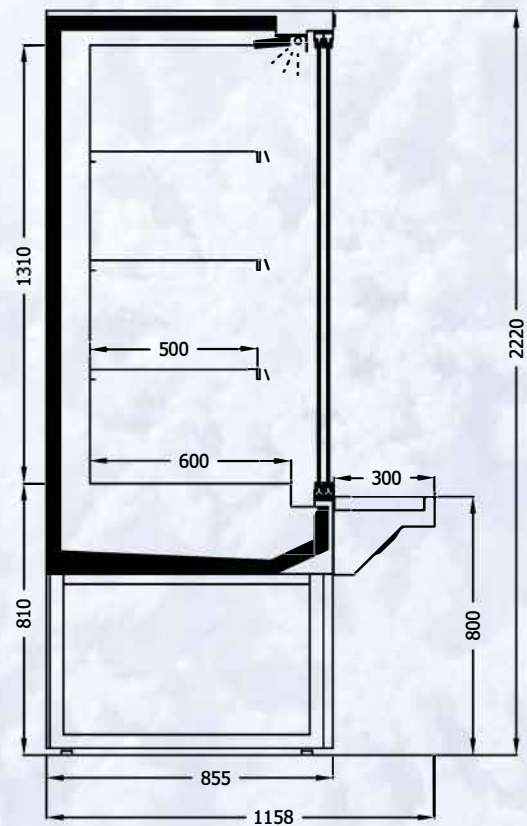



## MELBOURNE RB

DIŐTAN MOTORLU | REMOTE

MELBOURNE RB

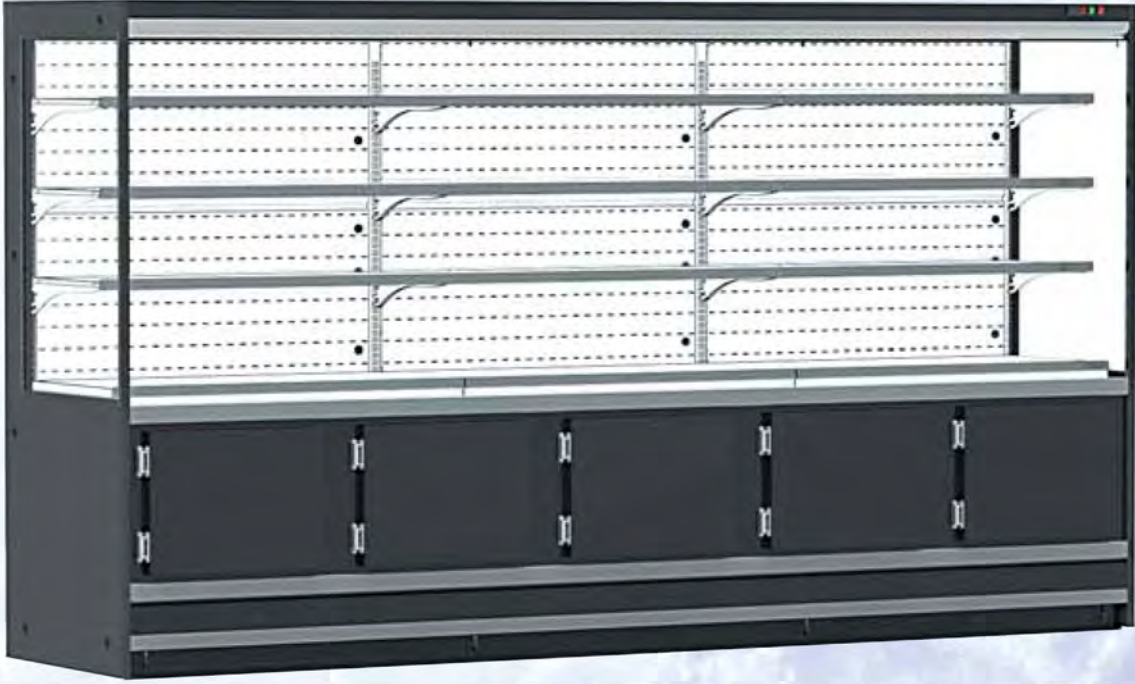

MELBOURNE RB DGD

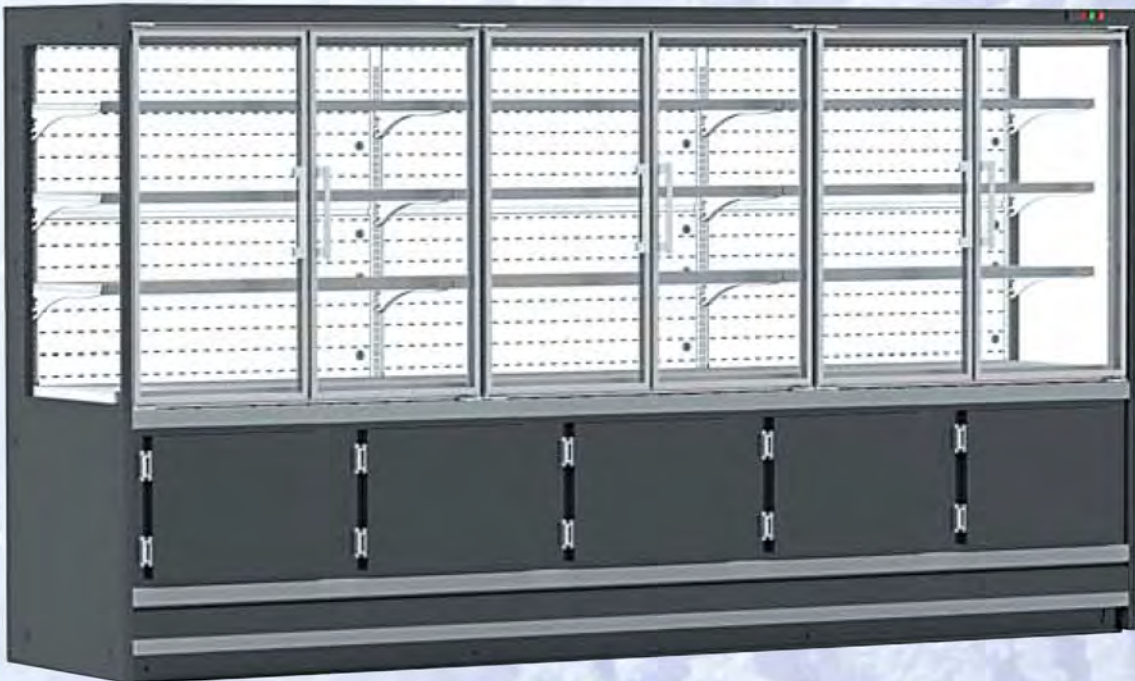

modules 1.25 1.875 2.500 3.750

# 3K SOĞUTMA REFRIGERATION

Melbourne RB  
58.A1.L

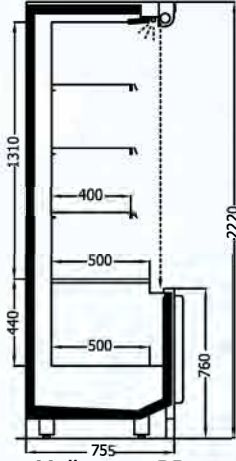

Melbourne RB  
68.A1.L

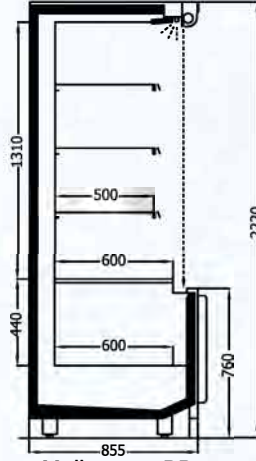

Melbourne RB  
78.A1.L

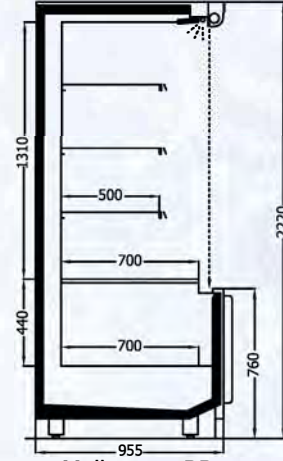

Melbourne RB  
58.A1.L.DGD

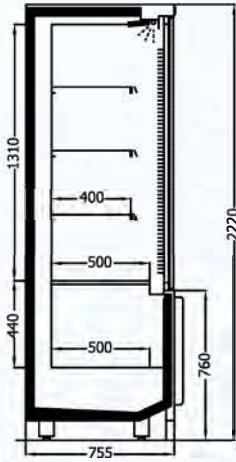

Melbourne RB  
68.A1.L.DGD

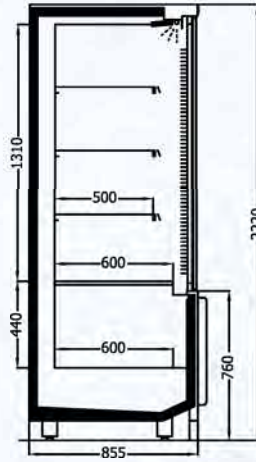

Melbourne RB  
78.A1.L.DGD

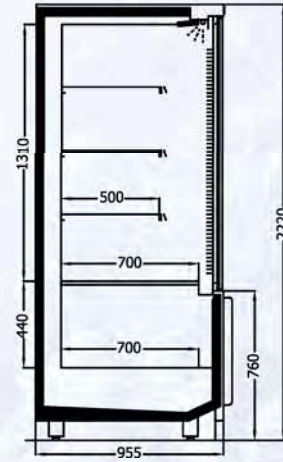

Melbourne RB  
58.A1

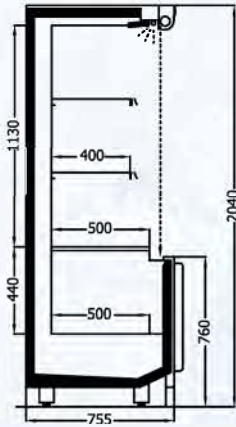

Melbourne RB  
68.A1

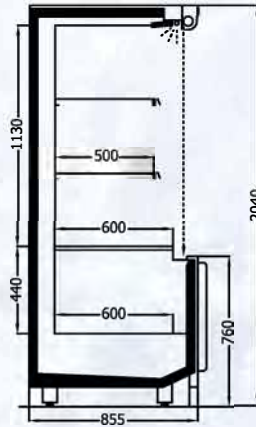

Melbourne RB  
78.A1

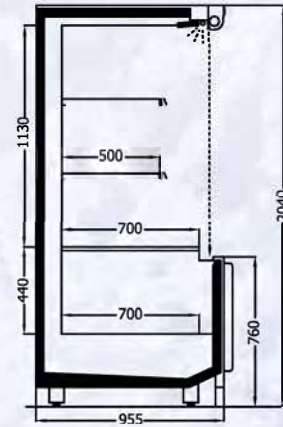

Melbourne RB  
58.A1.DGD

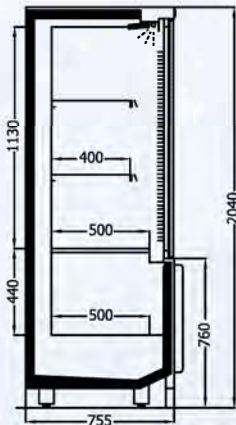

Melbourne RB  
68.A1.DGD

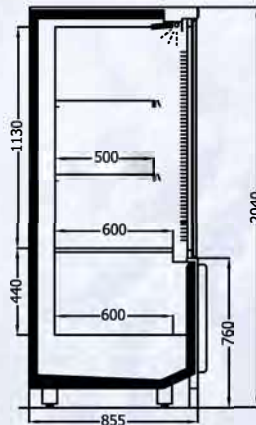

Melbourne RB  
78.A1.DGD

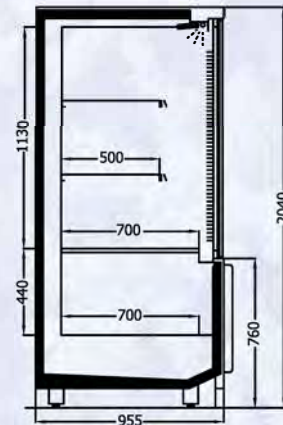

# MELBOURNE FV

DIŐTAN MOTORLU | REMOTE



modules 1.25 1.875 2.500 2.812 3.124 3.750

Melbourne FV 43.A1.L

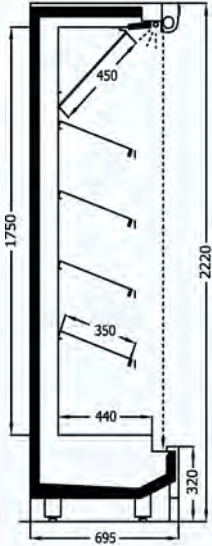

Melbourne FV 53.A1.L

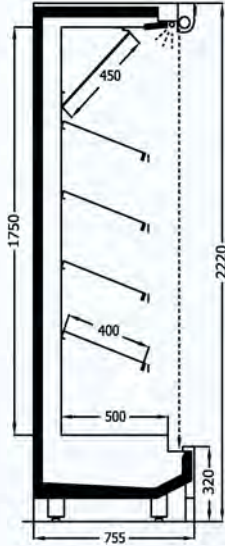

Melbourne FV 63.A1.L

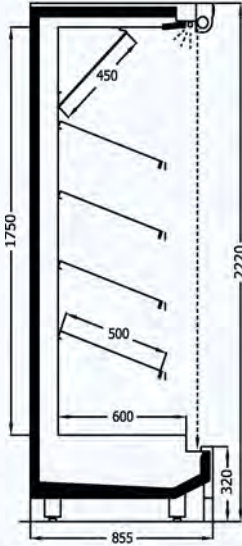

Melbourne FV 73.A1.L

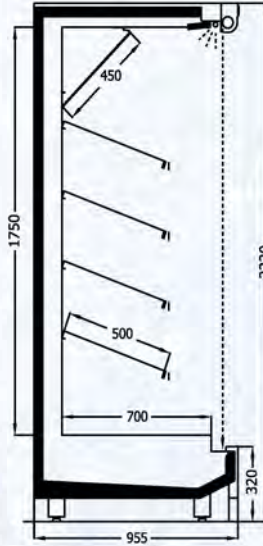

Melbourne FV 83.A1.L

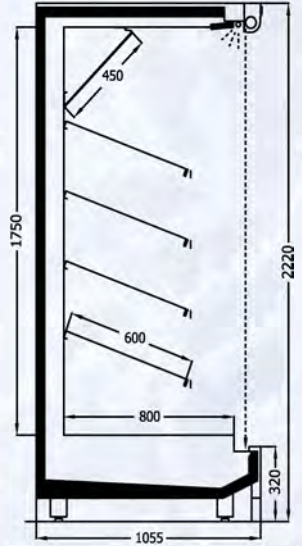

Melbourne FV 43.A1

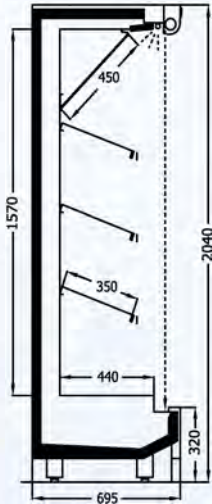

Melbourne FV 53.A1

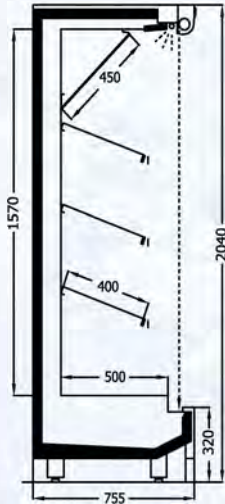

Melbourne FV 63.A1

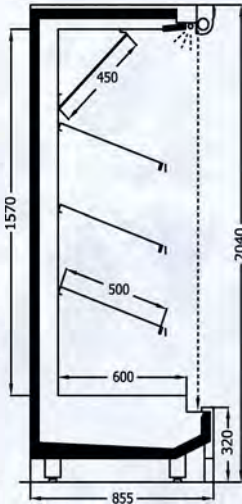

Melbourne FV 73.A1

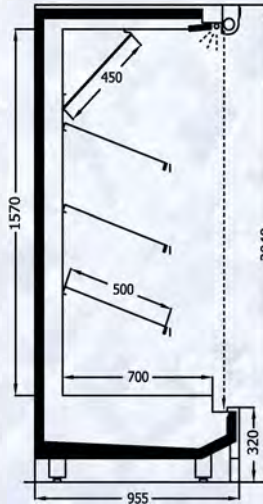

Melbourne FV 83.A1

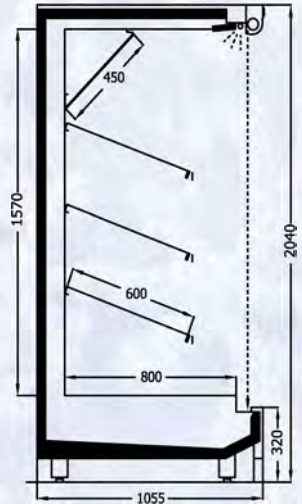

# DARWIN

DIŐTAN MOTORLU | REMOTE



modules 1.25 1.875 2.500

Darwin  
76.A1.L.DGD

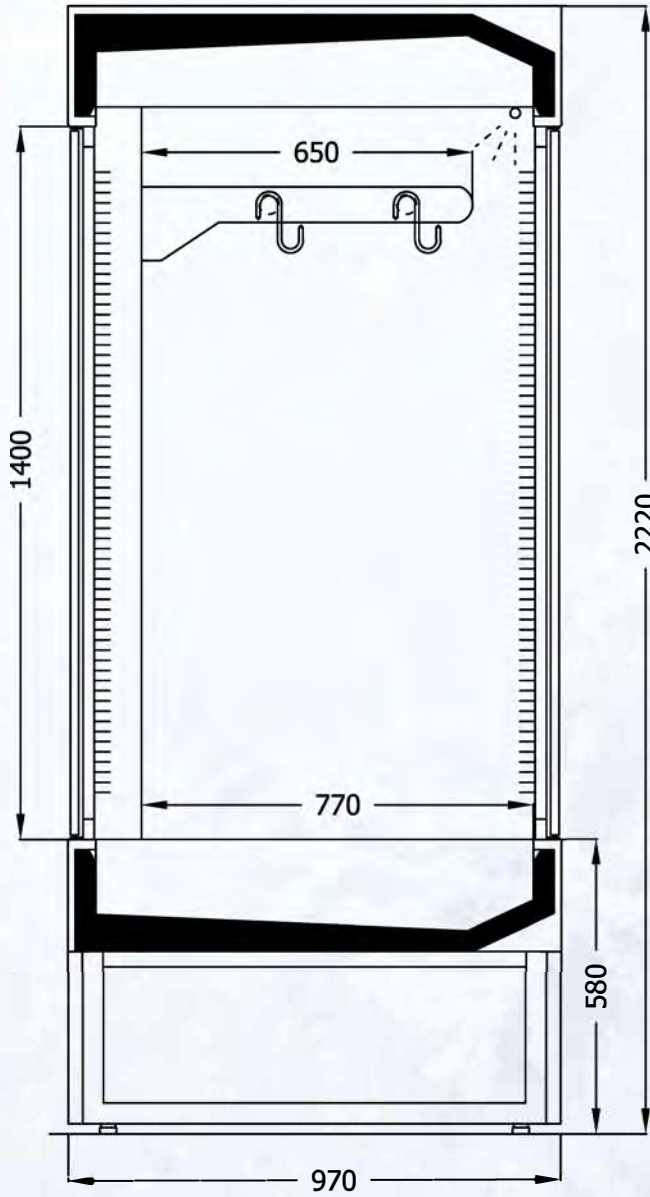

Darwin  
76.A1.L.DGD

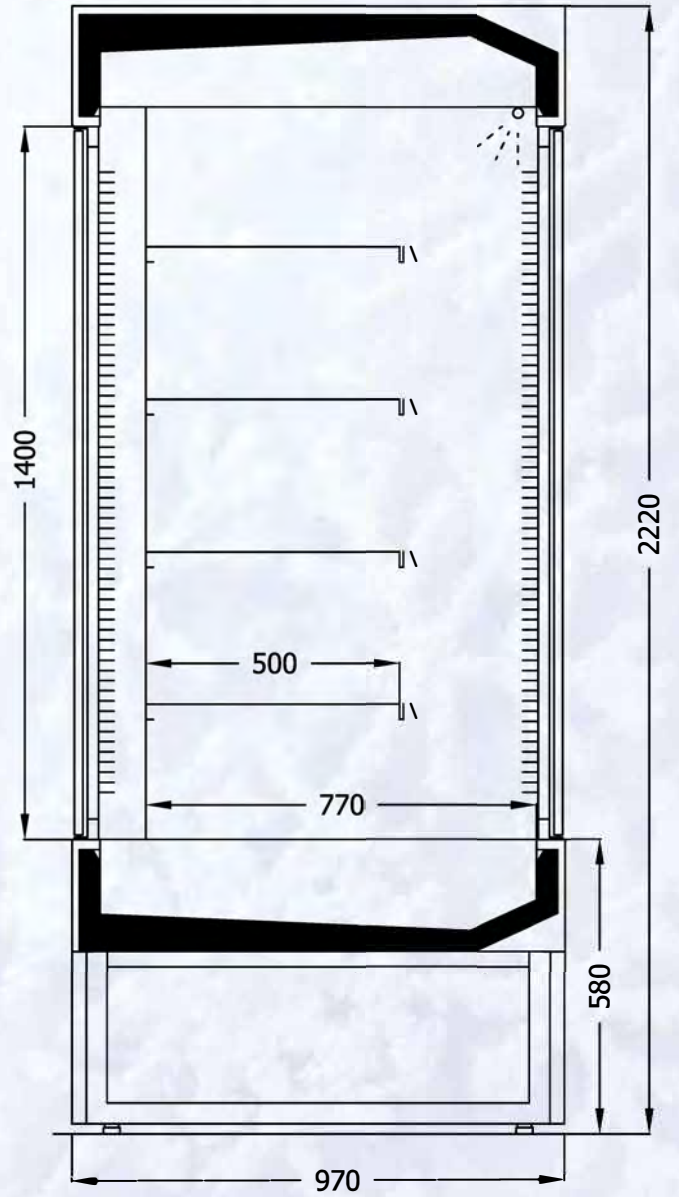

# MARLO

DIŐTAN MOTORLU | REMOTE

MARLO



MARLO ECO



modules 1.562 2.343 3.124 3.905

**Marlo  
53.A1.L**

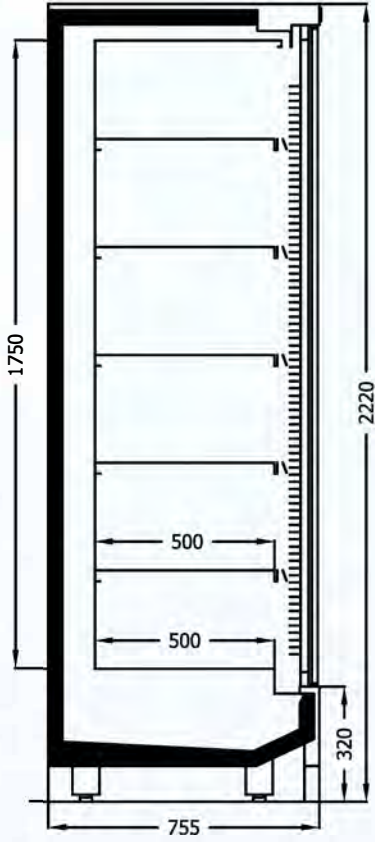

**Marlo  
63.A1.L**

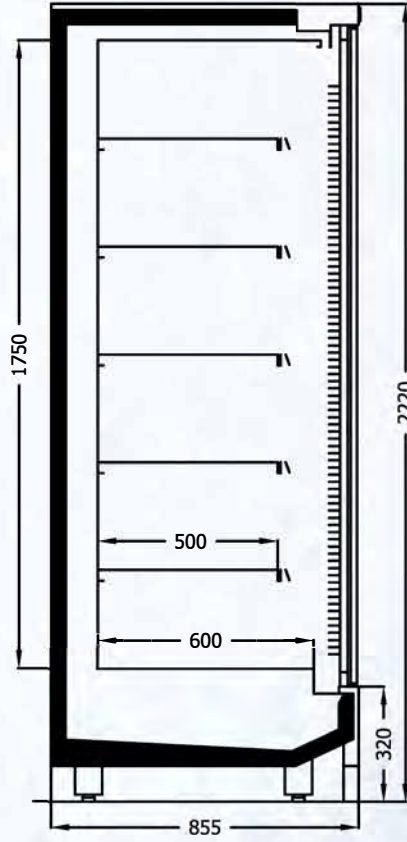

**Marlo Eco  
53.A1.L**

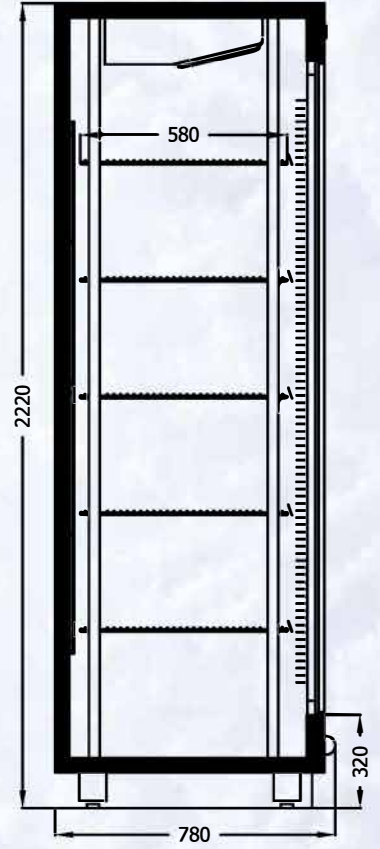

**Marlo  
53.A1**

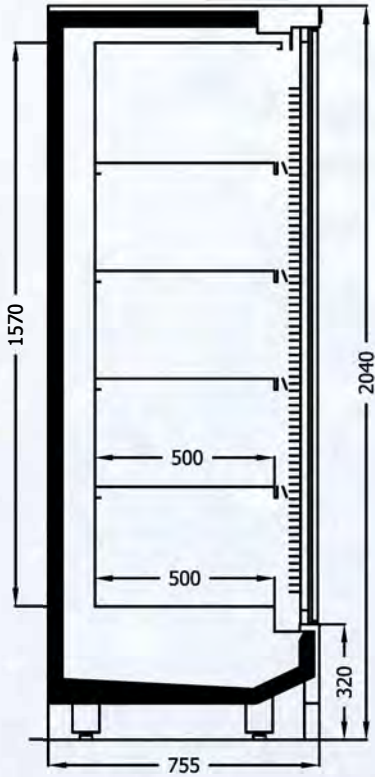

**Marlo  
63.A1**

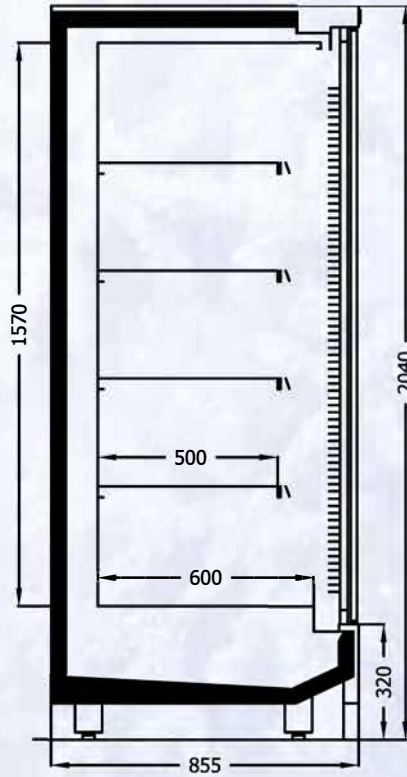

**Marlo Eco  
53.A1**

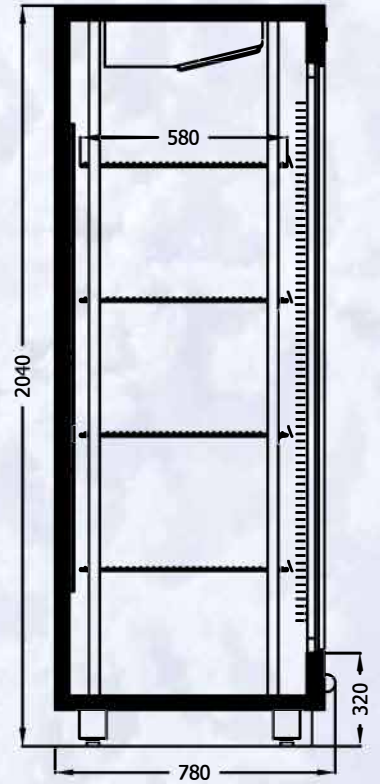



SÜTLÜK | MULTIDECKS

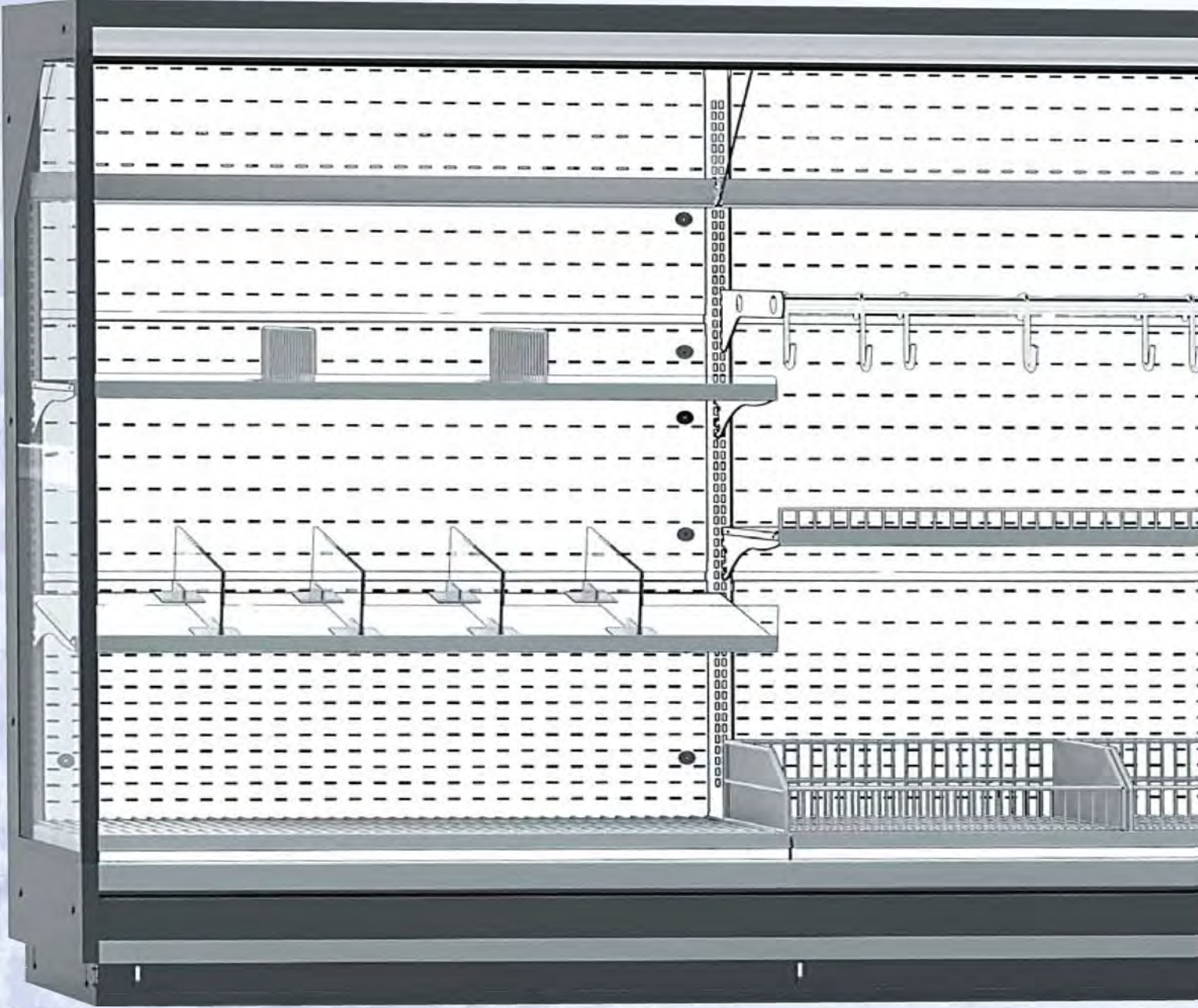

DIŐTAN MOTORLU | REMOTE

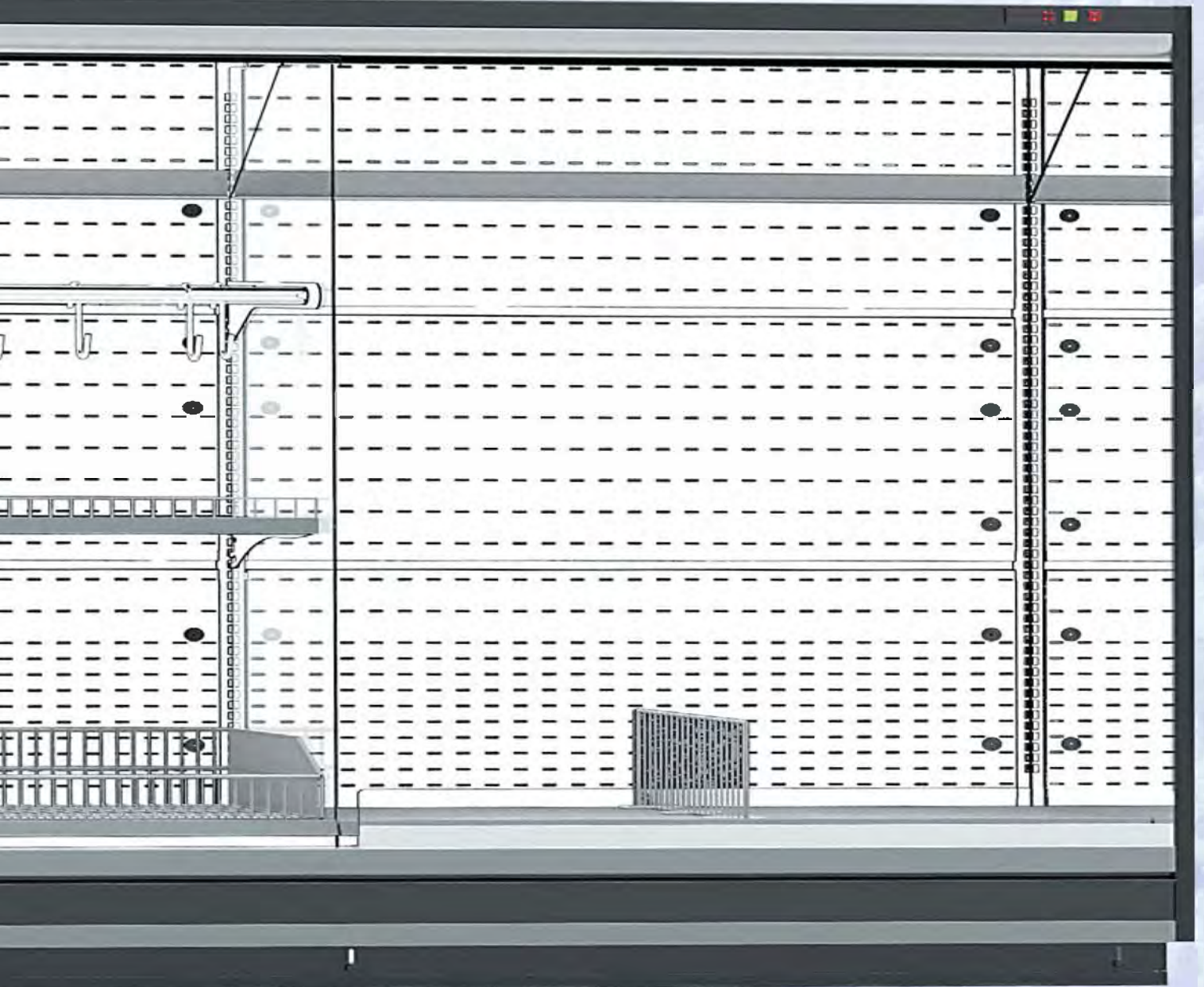

# MARBELLA

DIŐTAN MOTORLU | REMOTE

MARBELLA



MARBELLA D-SGD

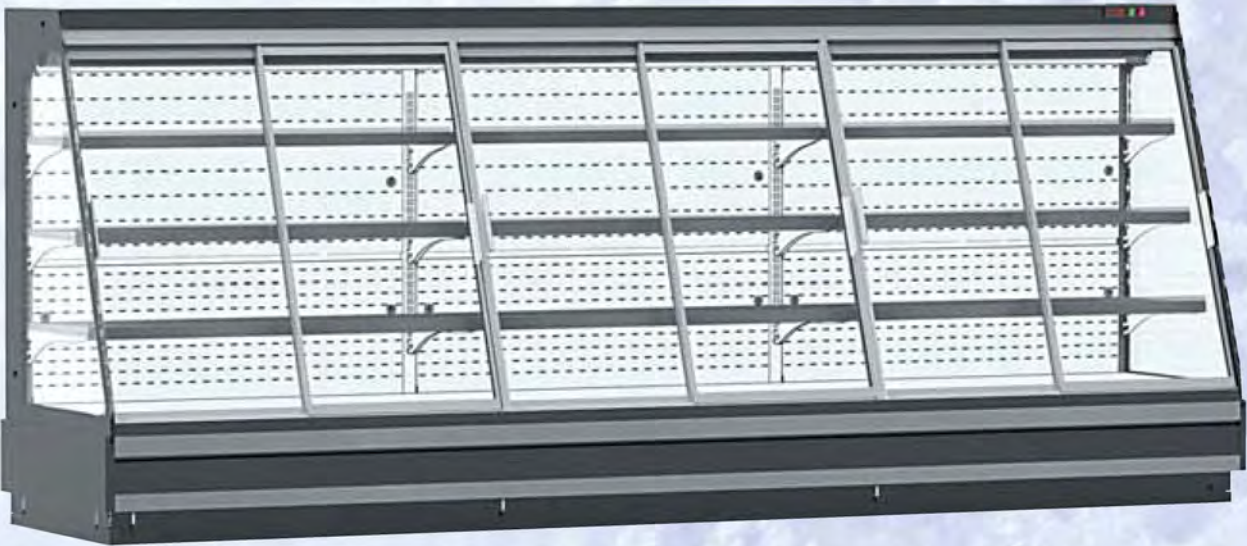

modules 1.25 1.875 2.500 3.124 3.750



# MANAMA

DIŐTAN MOTORLU | REMOTE



modules 1.562 2.340 3.124 3.905

Manama  
63.A1.L

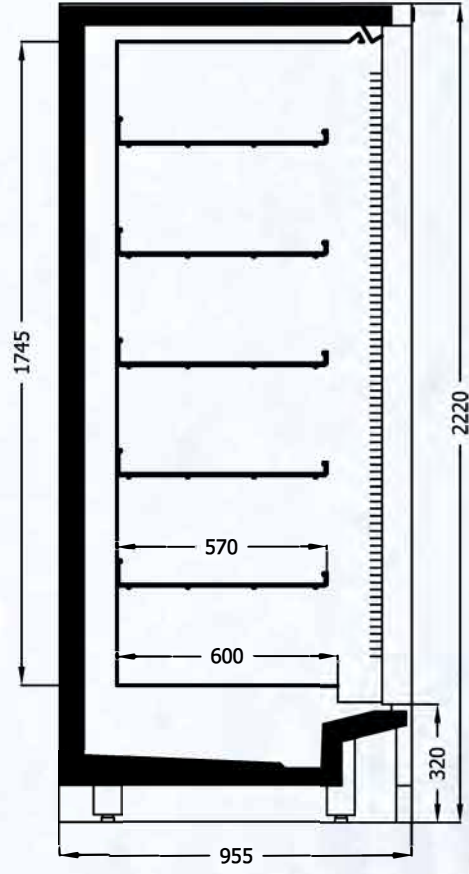

Manama  
63.A1

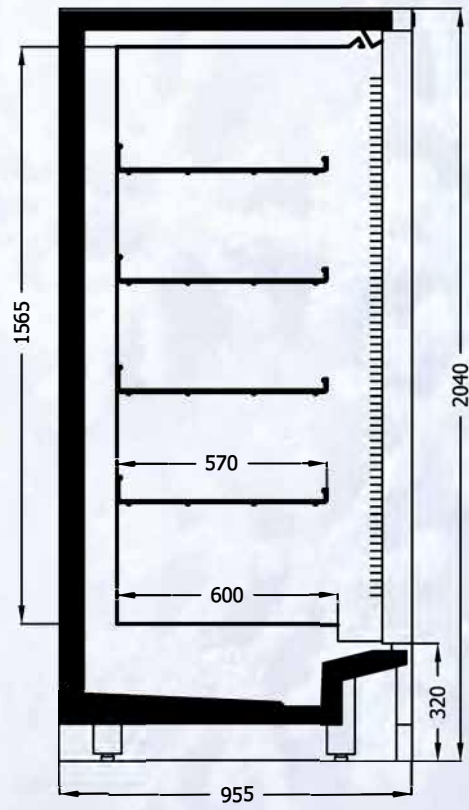

# SPARTA CG-FG

İÇTEN MOTORLU | PLUG - IN

SPARTA CG

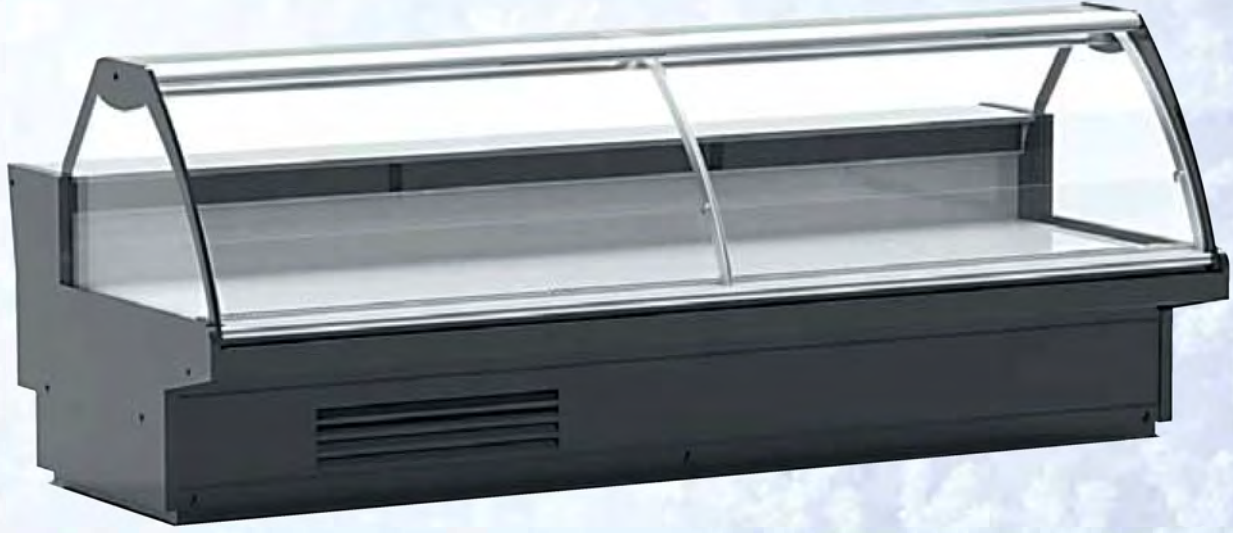

SPARTA FG



modules 0.938 1.25 1.875 2.500 2.812

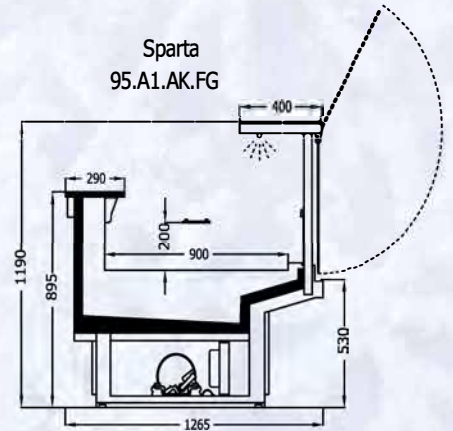
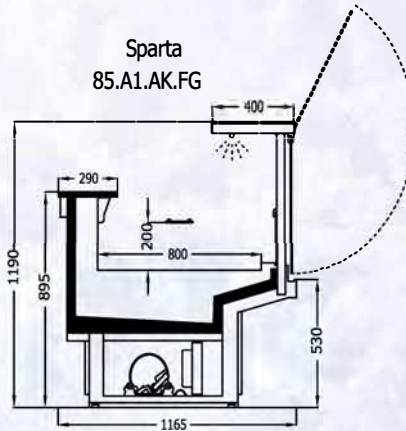
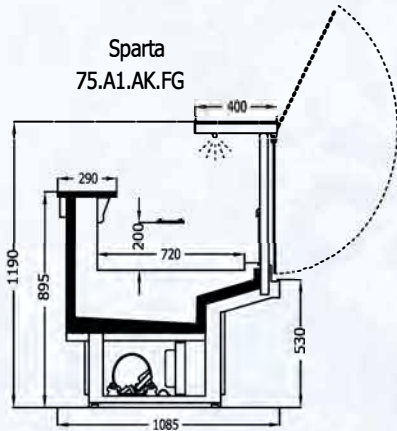
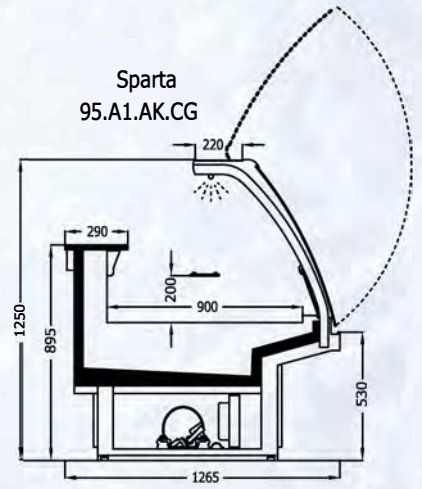
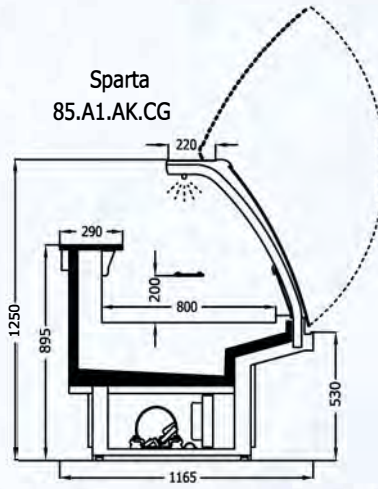
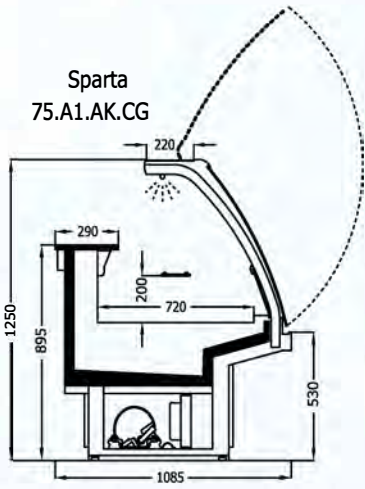



# SPARTA AFG

İÇTEN MOTORLU | PLUG - IN



modules 0.938 1.25 1.875 2.500 2.812

Sparta  
75.A1.AK.AFG

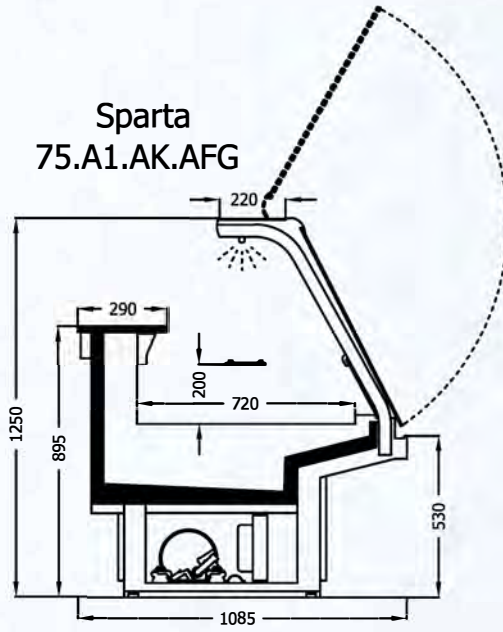

Sparta  
85.A1.AK.AFG

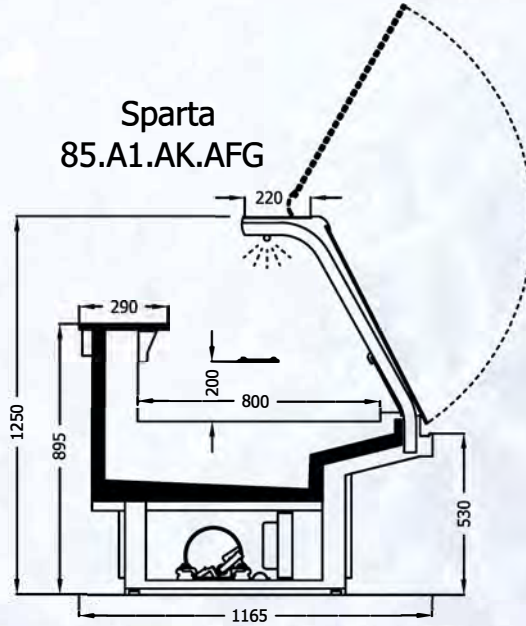

Sparta  
95.A1.AK.AFG

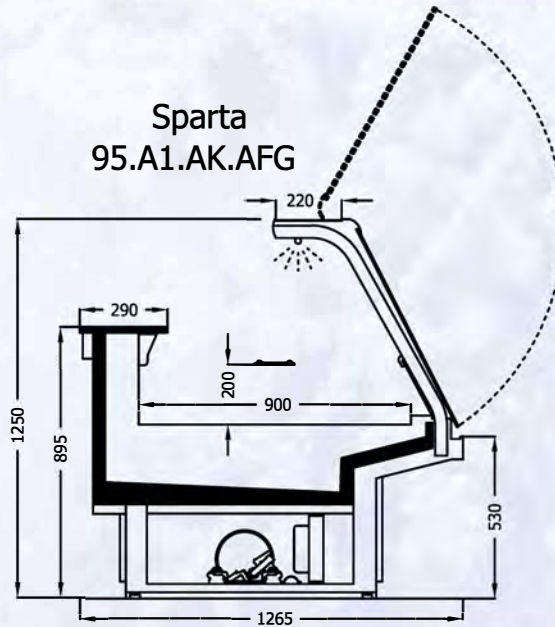

# SPARTA SS.CG-FG

İÇTEN MOTORLU | PLUG-IN

SPARTA SS.CG

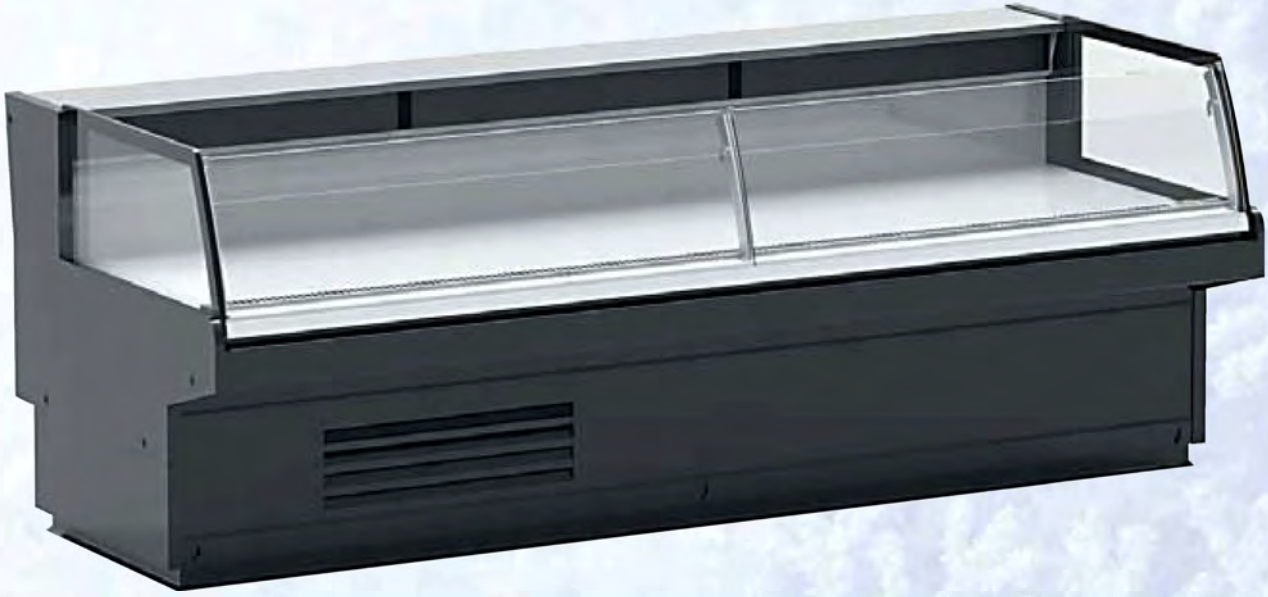

SPARTA SS.FG

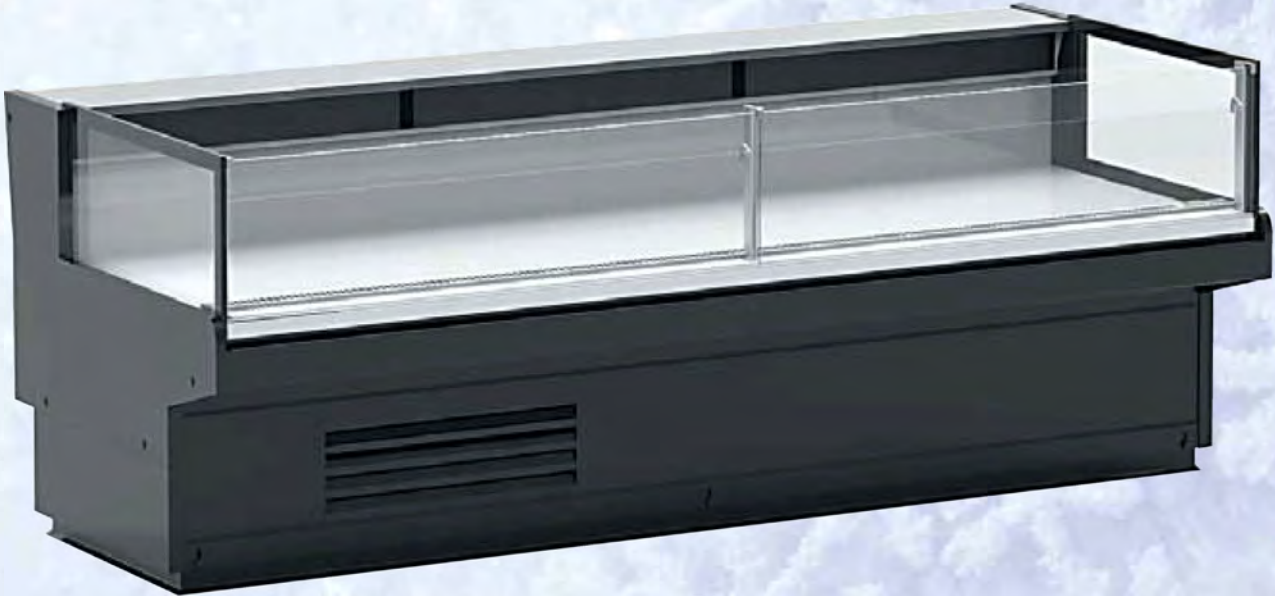

modules 0.938 1.25 1.875 2.500 2.812

**Sparta**  
**75.A1.AK.SS.CG**

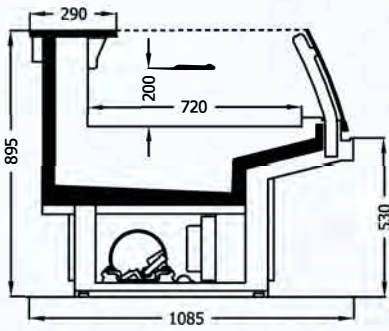

**Sparta**  
**85.A1.AK.SS.CG**

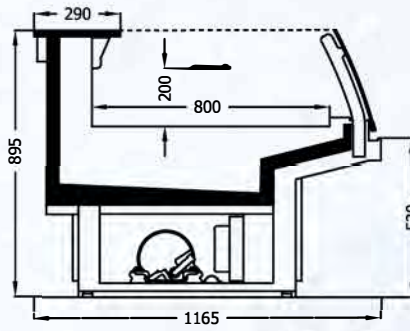

**Sparta**  
**95.A1.AK.SS.CG**

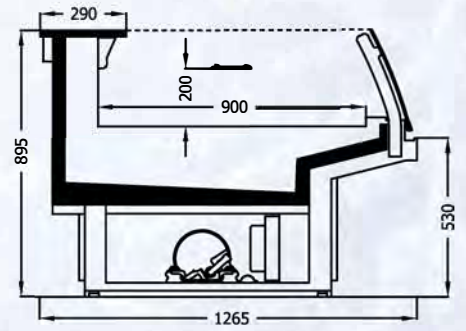

**Sparta**  
**75.A1.AK.SS.FG**

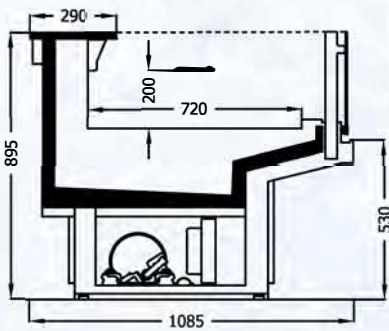

**Sparta**  
**85.A1.AK.SS.FG**

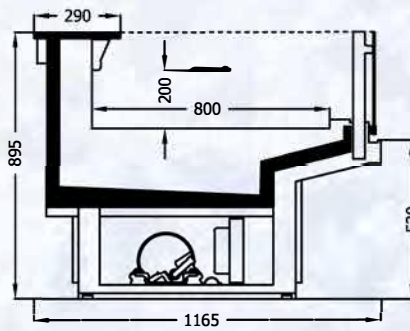

**Sparta**  
**95.A1.AK.SS.FG**

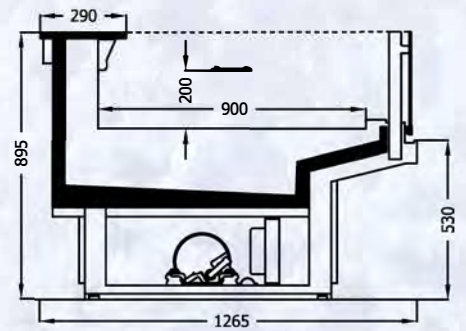

## STOW FG

İÇTEN MOTORLU | PLUG-IN



modules 0.938 1.25 1.875 2.500 2.812

Stow  
85.A1.AK.FG

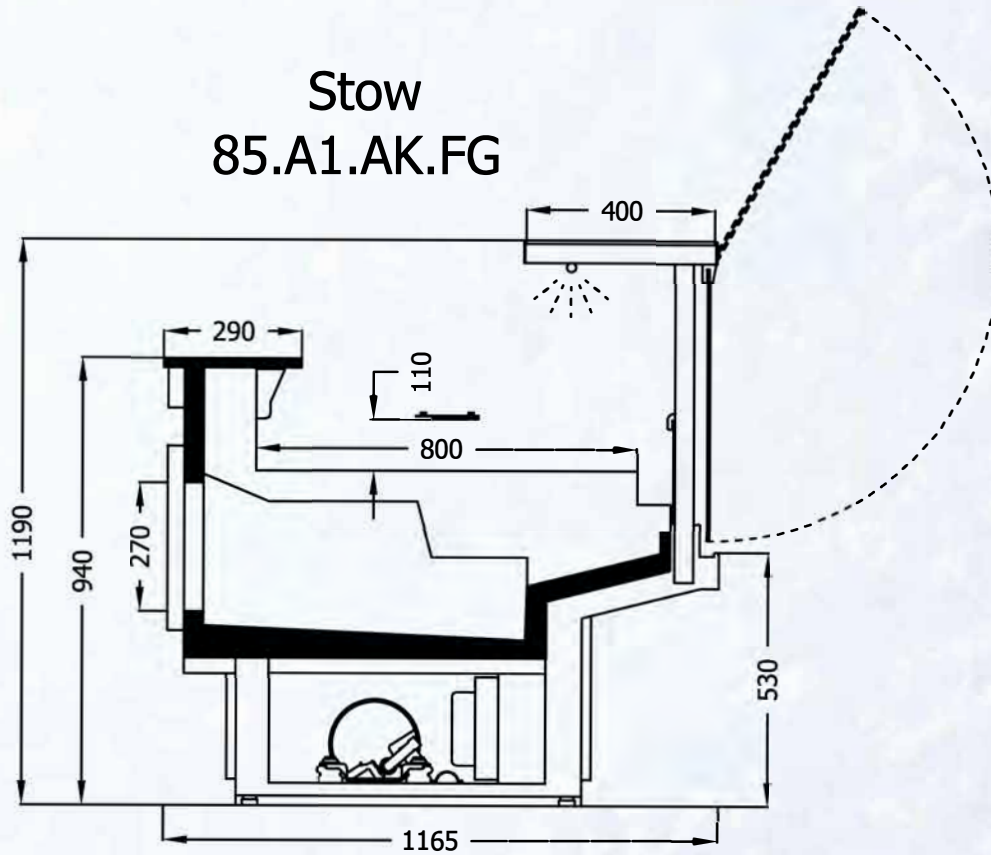

Stow  
95.A1.AK.FG

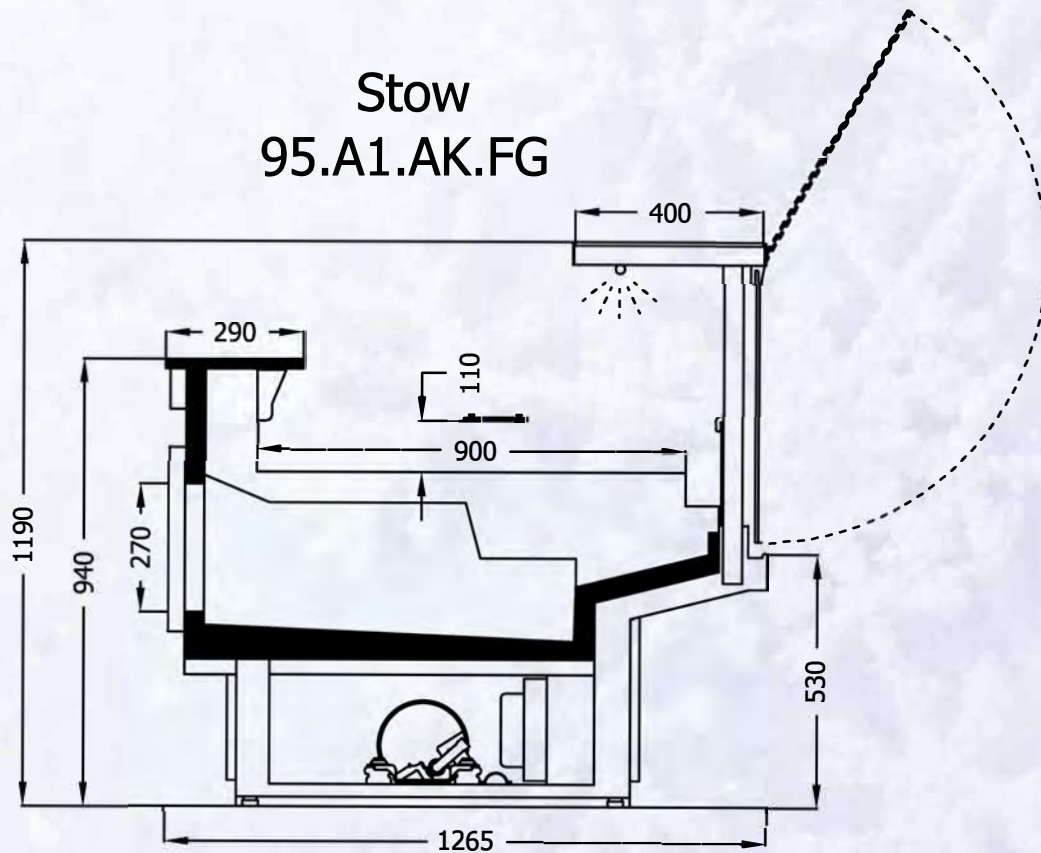

# HAWAII

İÇTEN MOTORLU | PLUG-IN

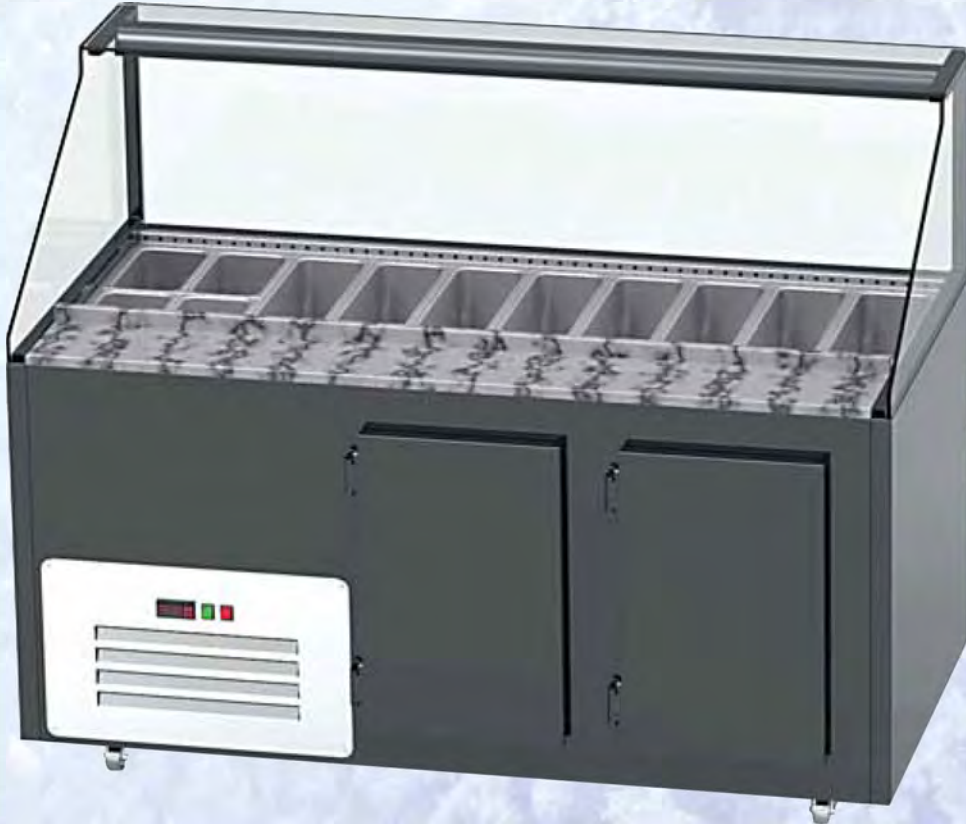

# Hawai 850\*1300

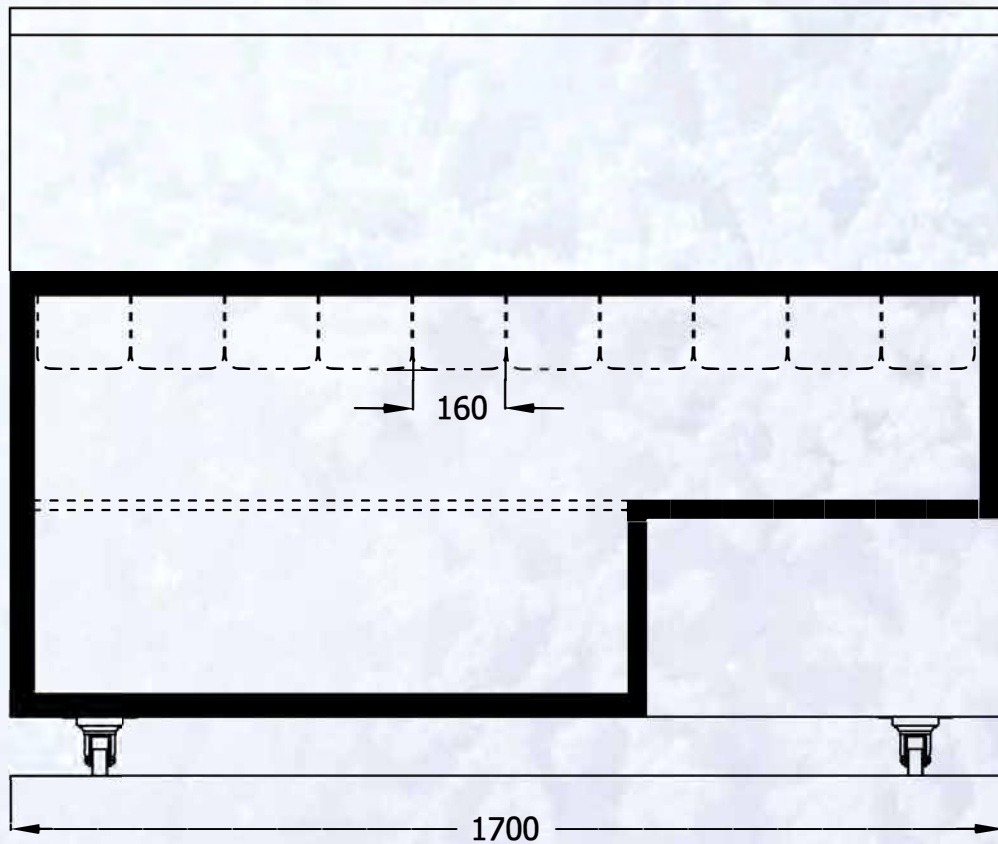
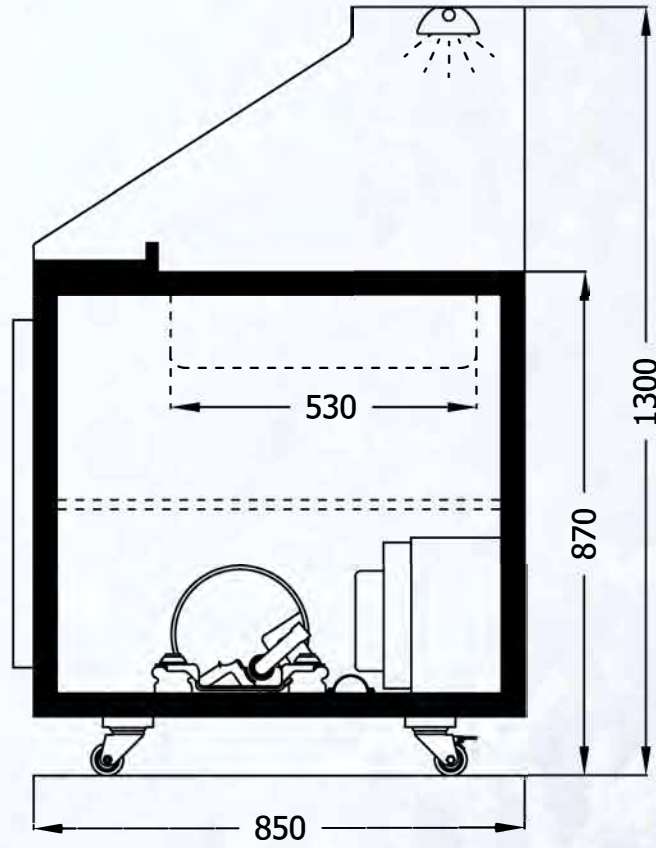



# ŞARKÜTERİ | COUNTERS

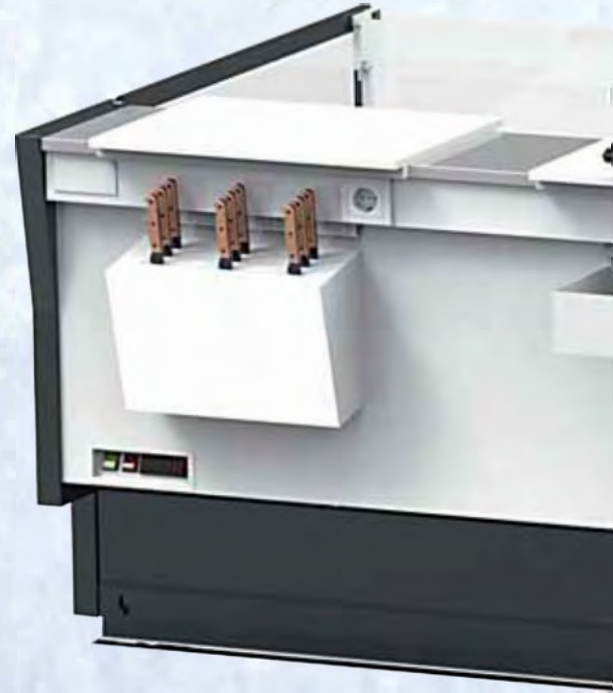

İÇTEN MOTORLU | PLUG - IN



# MANDURAH

İÇTEN MOTORLU | PLUG-IN

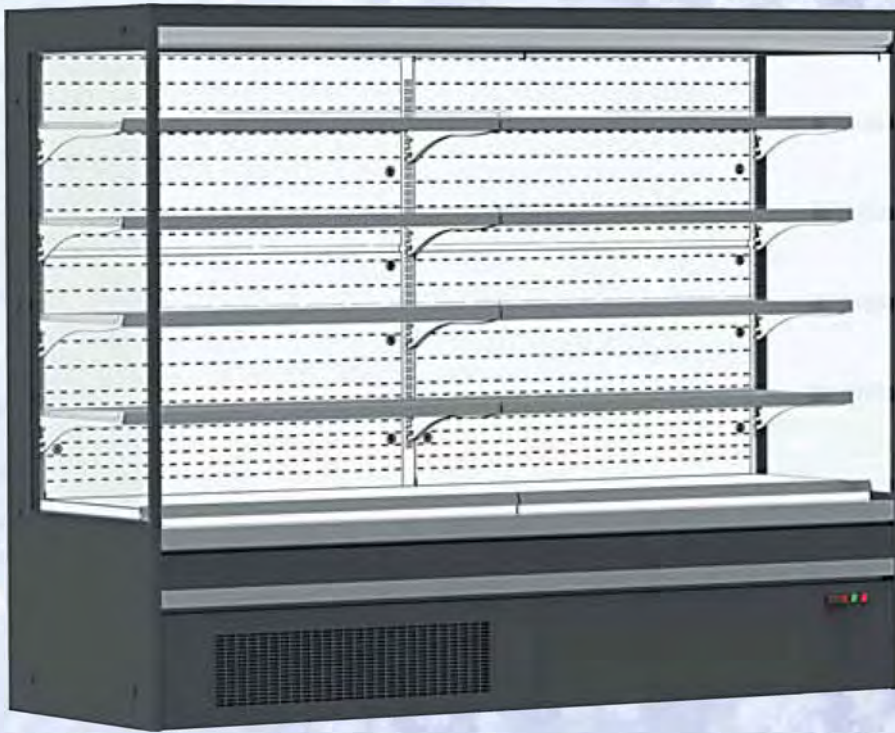

Mandurah  
46.A1.L

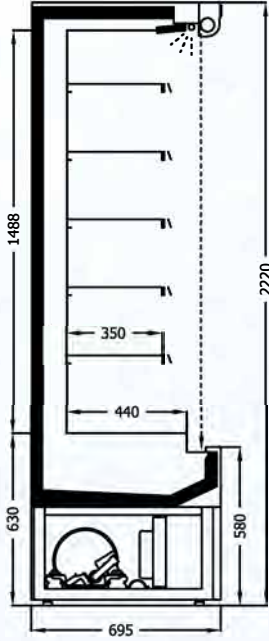

Mandurah  
56.A1.L

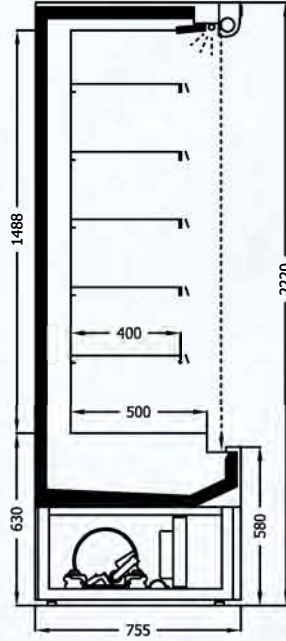

Mandurah  
66.A1.L

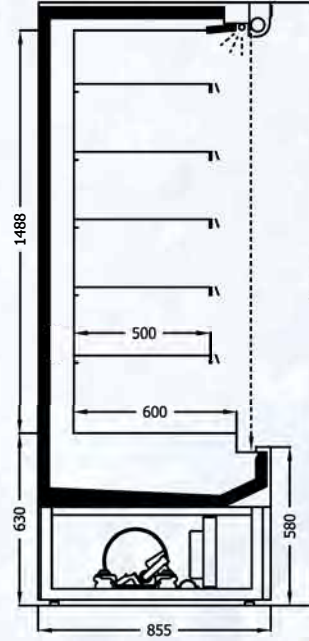

Mandurah  
76.A1.L

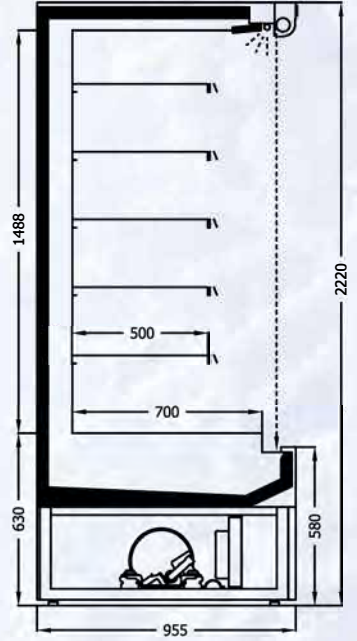

Mandurah  
46.A1

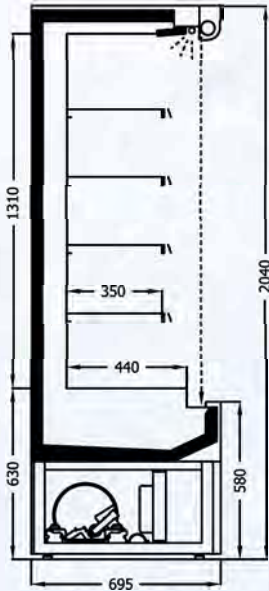

Mandurah  
56.A1

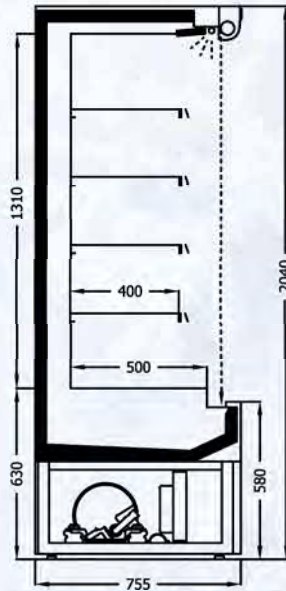

Mandurah  
66.A1

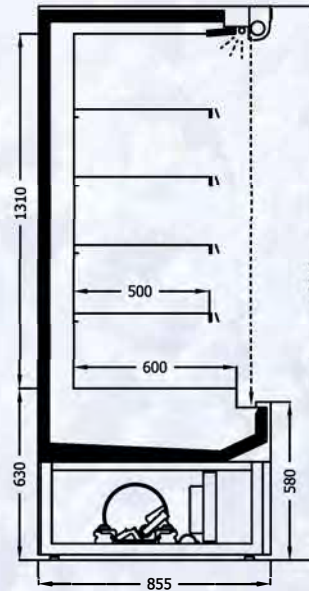

Mandurah  
76.A1

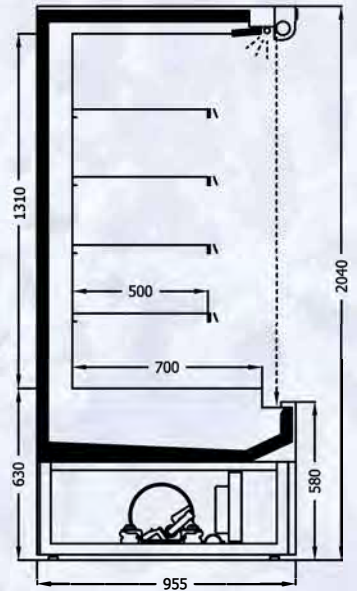

# MANDURAH DGD

İÇTEN MOTORLU | PLUG-IN



modules 0.938 1.25 1.875 2.500

Mandurah  
46.A1.L.DGD

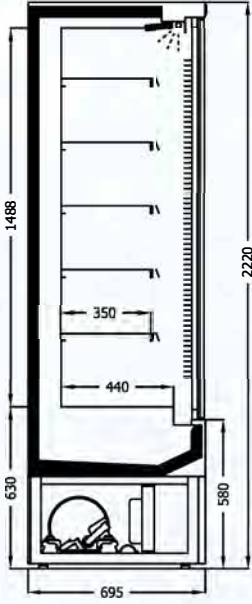

Mandurah  
56.A1.L.DGD

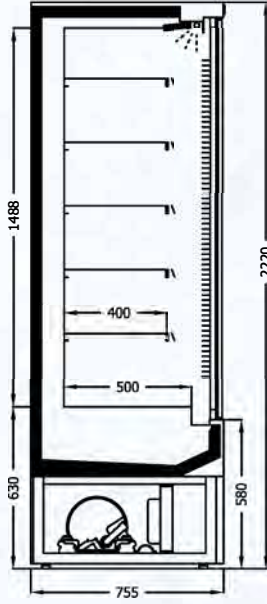

Mandurah  
66.A1.L.DGD

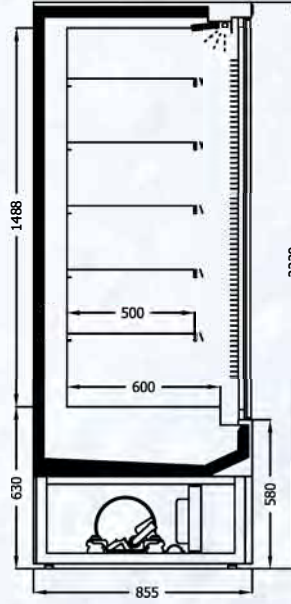

Mandurah  
76.A1.L.DGD

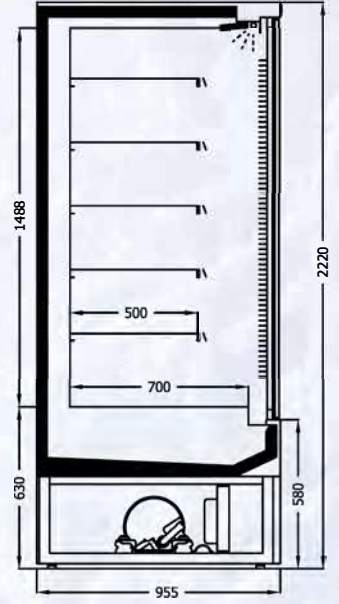

Mandurah  
46.A1.DGD

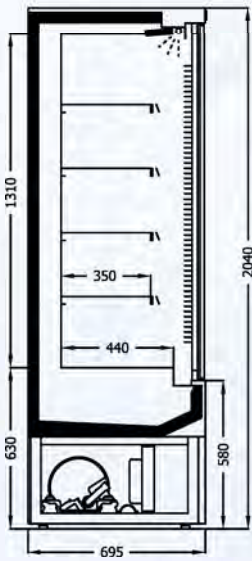

Mandurah  
56.A1.DGD

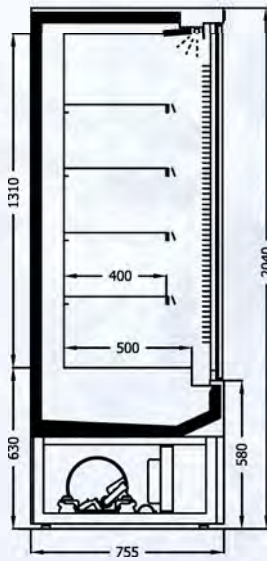

Mandurah  
66.A1.DGD

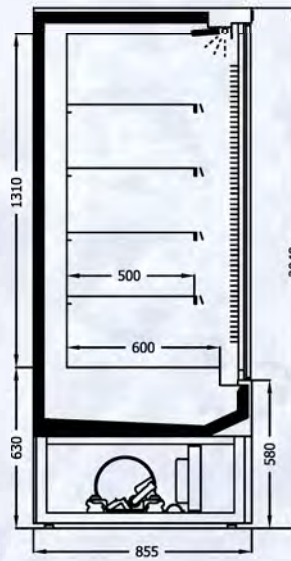

Mandurah  
76.A1.DGD

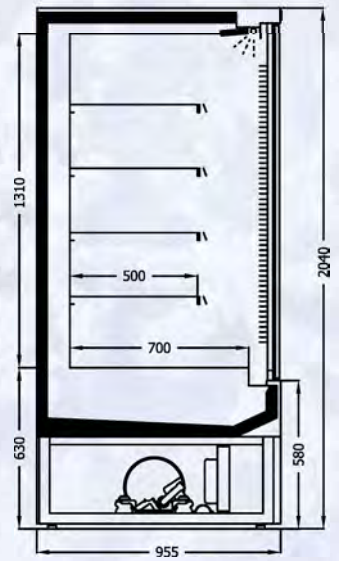

# MANDURAH FV

İÇTEN MOTORLU | PLUG-IN

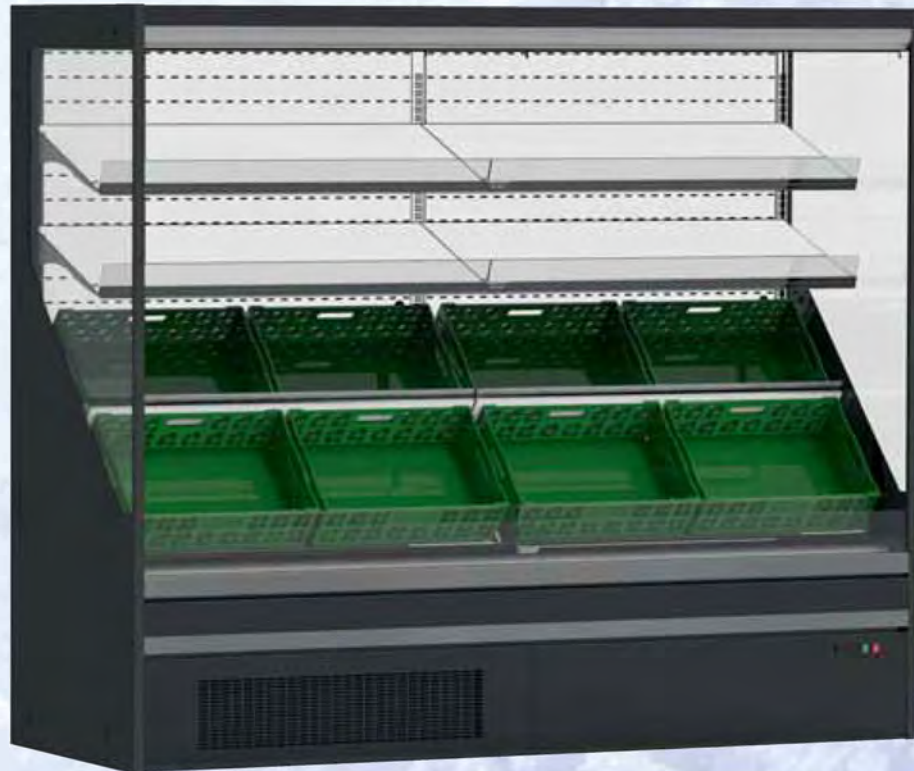

modules 1.25 1.875 2.500

65

Mandurah FV  
76.A1.L

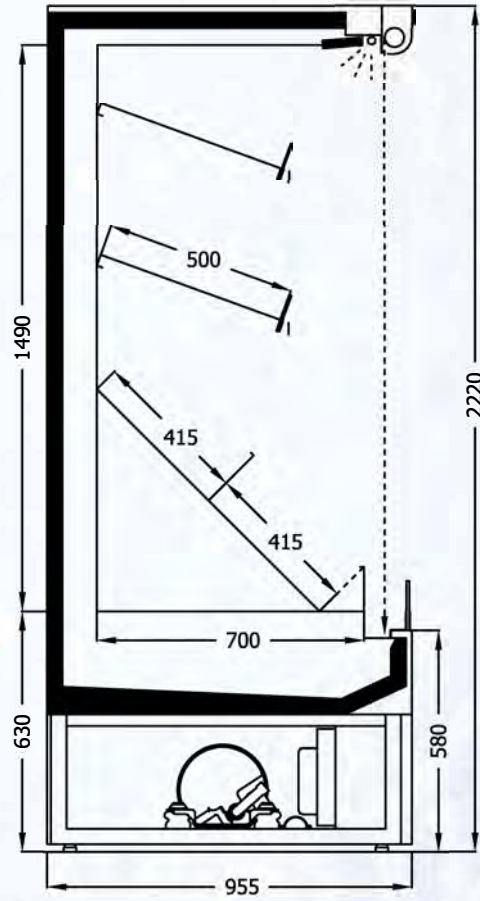

Mandurah FV  
76.A1

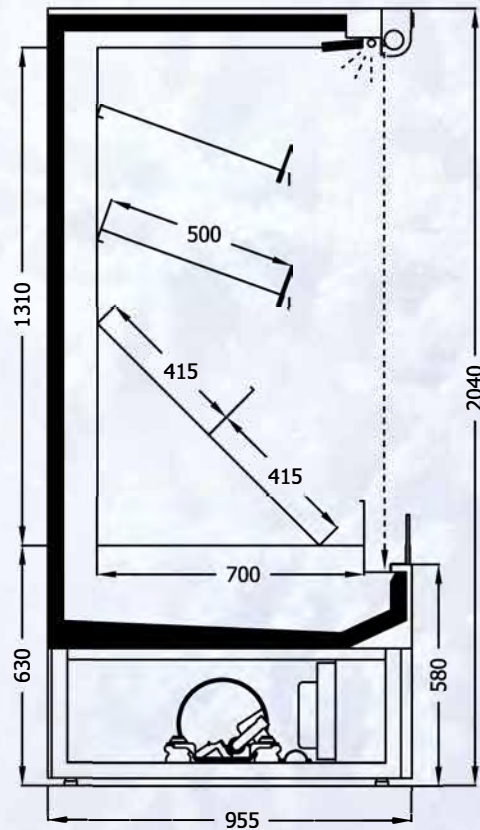



## DRY AGED

İÇTEN MOTORLU | PLUG-IN



modules 1.25 1.875 2.500

# DRY-AGED 76.A1.L.DGD

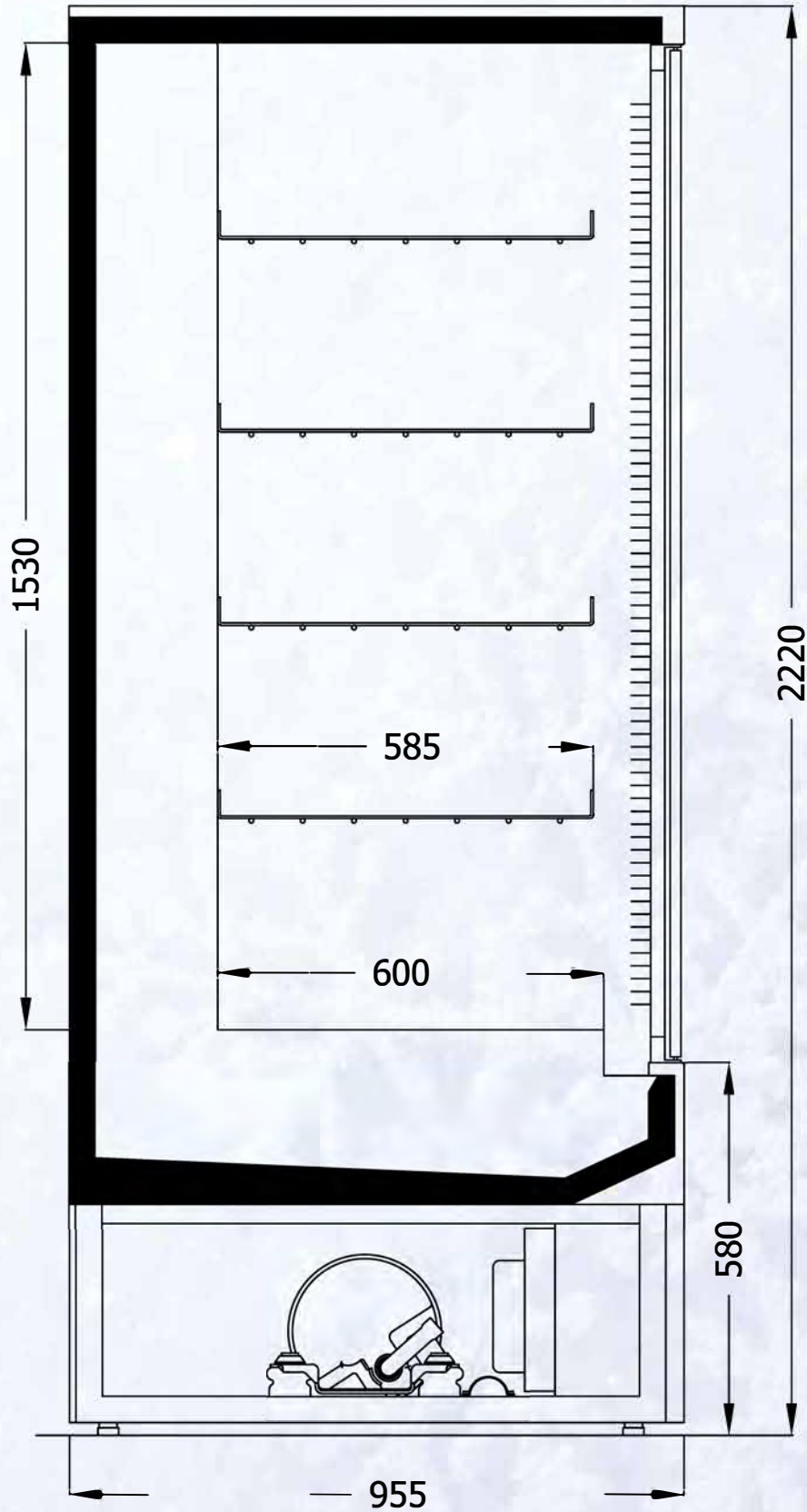

# MACON

İÇTEN MOTORLU | PLUG-IN

MACON D-SGD



MACON

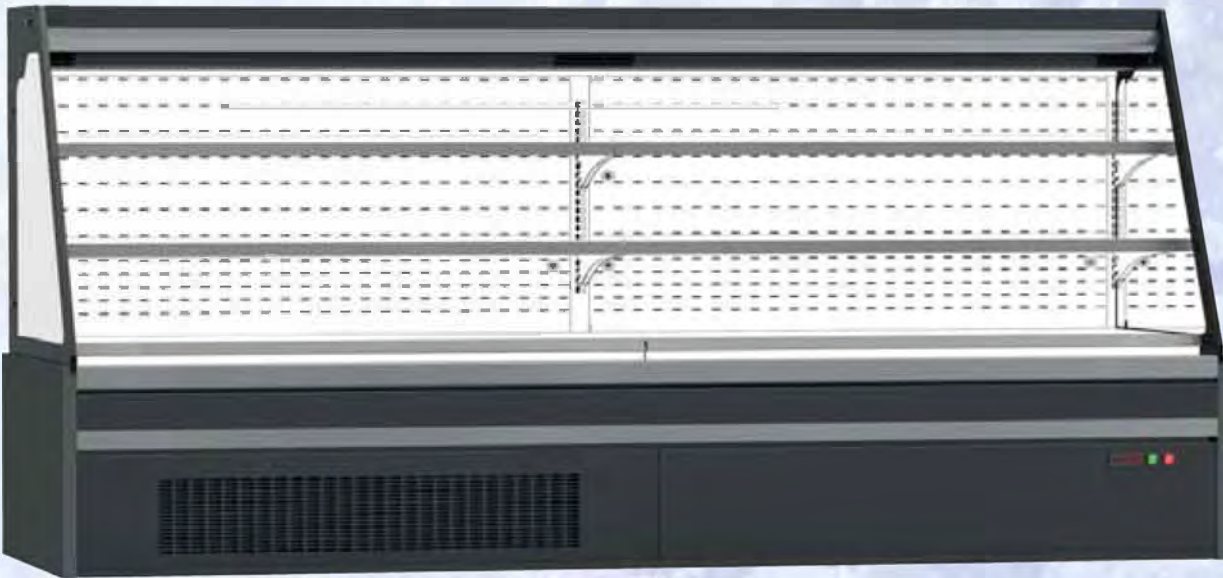

modules 0.938 1.25 1.875 2.500

**Macon**  
**56.A1 H:1550**

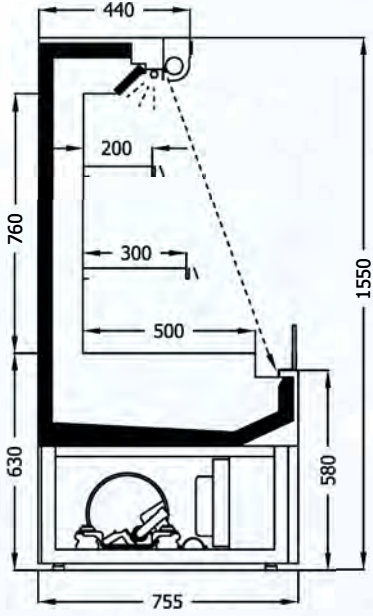

**Macon**  
**66.A1 H:1550**

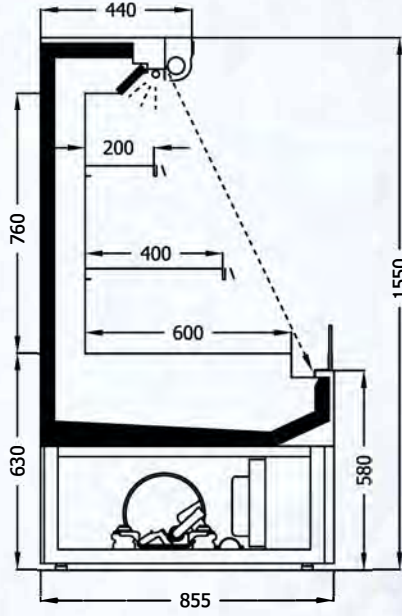

**Macon**  
**76.A1 H:1550**

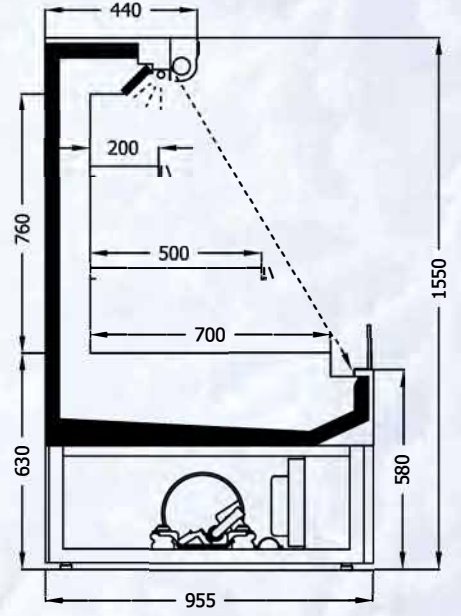

**Macon**  
**56.A1.D-SGD H:1550**

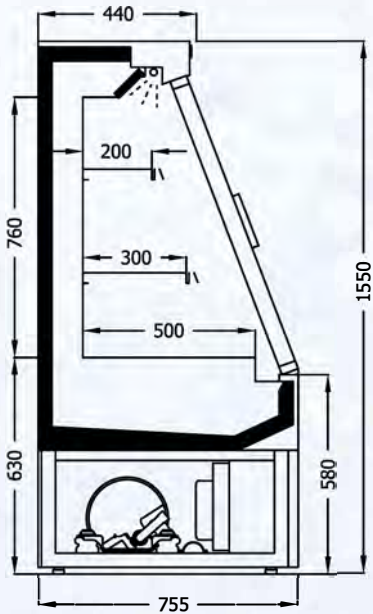

**Macon**  
**66.A1.D-SGD H:1550**

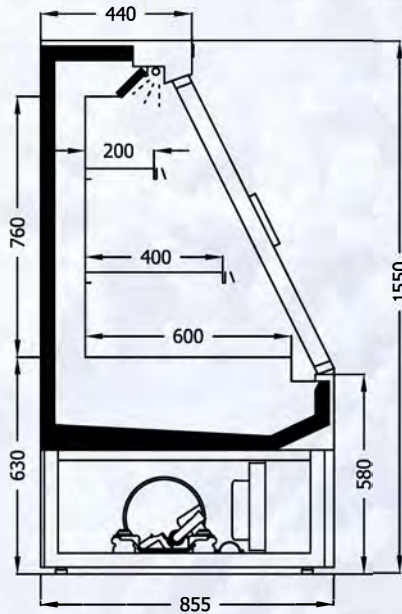

**Macon**  
**76.A1.D-SGD H:1550**

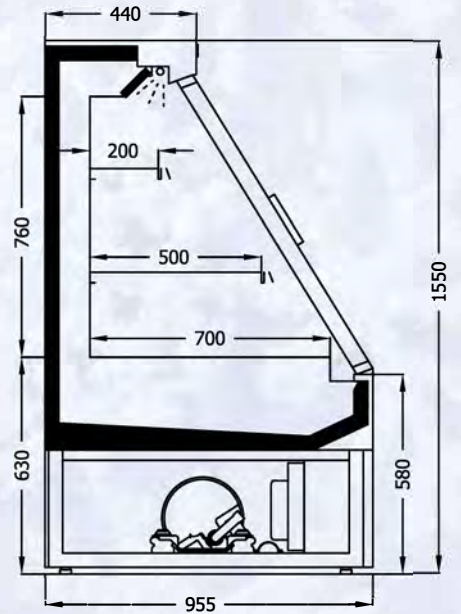

# BRISBANE

İÇTEN MOTORLU | PLUG-IN



modules 1.20 2.00

**BRISBANE**  
**50.A1**

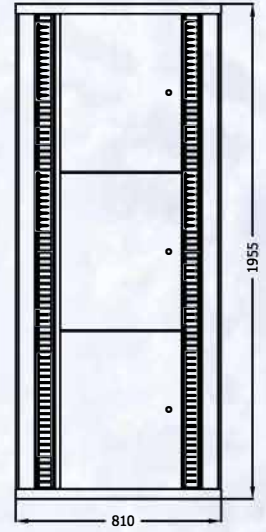
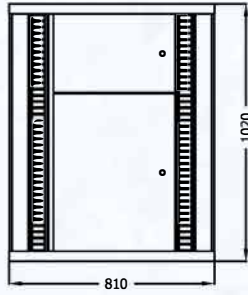
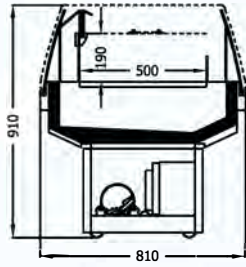

**BRISBANE**  
**70.A1**

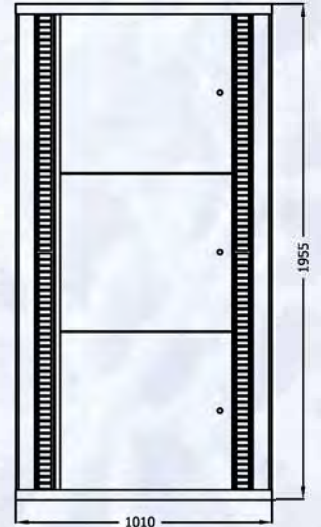
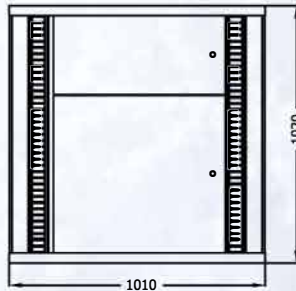
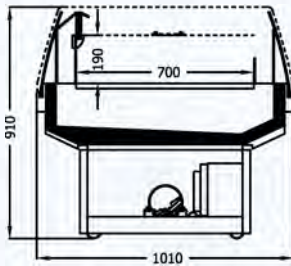

**BRISBANE**  
**80.A1**

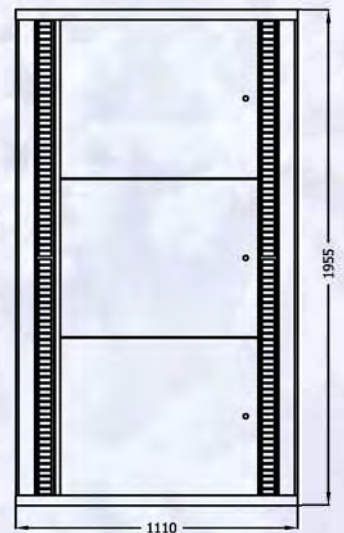
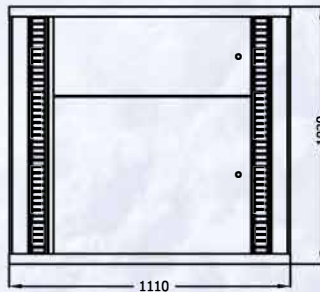
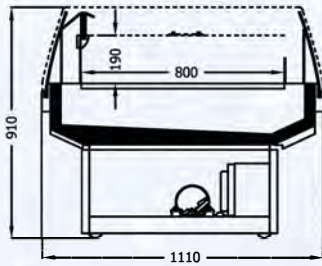

# BRISBANE NC. O-SGD

İÇTEN MOTORLU | PLUG-IN



BRISBANE NC



BRISBANE O-SGD

modules 1.20 2.00

**BRISBANE**  
**50.A1.NC**

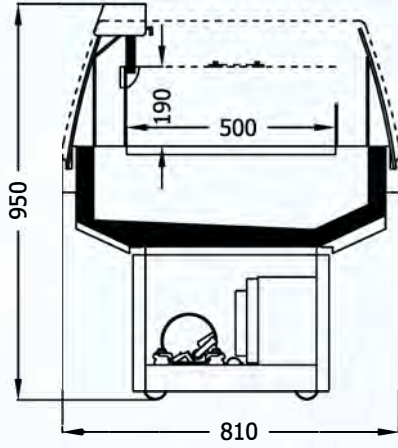

**BRISBANE**  
**50.A1.O-SGD**

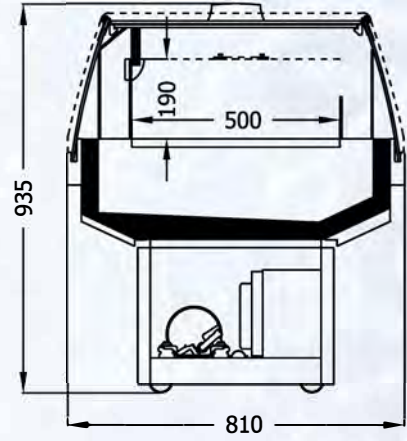

**BRISBANE**  
**70.A1.NC**

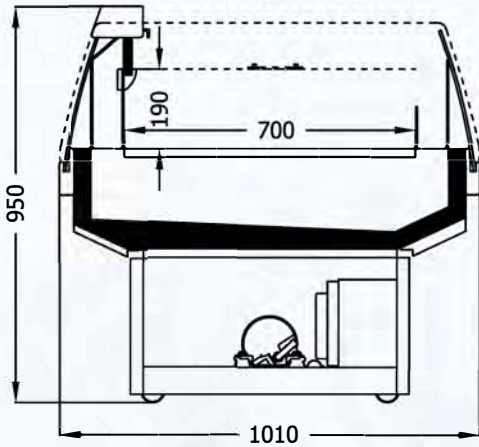

**BRISBANE**  
**70.A1.O-SGD**

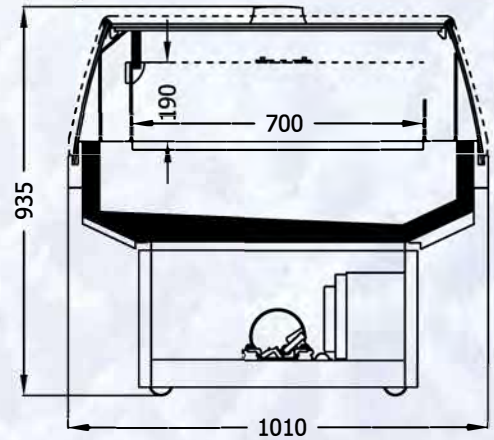

**BRISBANE**  
**80.A1.NC**

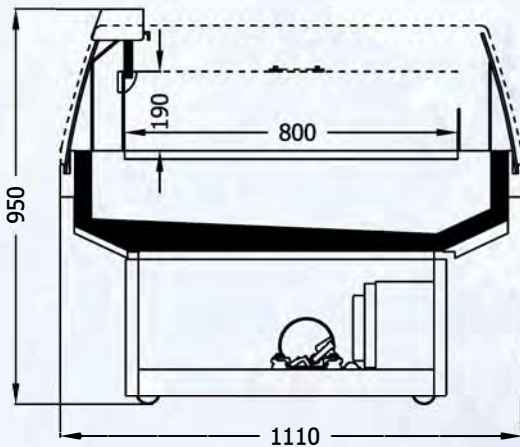

**BRISBANE**  
**80.A1.O-SGD**

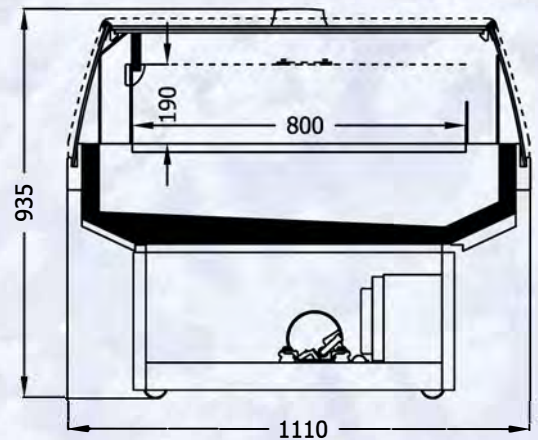



# SOĞUK HAVA DEPOLARI

## COLD ROOMS



# SOĞUTMA SİSTEMLERİ

## COOLING SYSTEMS



YETKİLİ SATICI

**3K**  
**SOĞUTMA**  
**REFRIGERATION**

3K Soğutma Isıtma LTD.ŞTİ.

5116Sokak No:7/1 Çamdibi/Bornova - İZMİR  
Telefon : 0232 462 48 03(pbx)  
Fax : 0232 462 48 03  
Mobil : 0530 543 90 13 - 0534 860 24 32  
Email: servis@3ksogutma.com.tr  
muhassebe@3ksogutma.com.tr  
www.3ksogutma.com.tr